

**Victorian Certificate of Education
2017****General Achievement Test****Wednesday 14 June 2017****Reading time: 10.00 am to 10.15 am (15 minutes)****Writing time: 10.15 am to 1.15 pm (3 hours)****QUESTION BOOK****Structure of book**

<i>Type of questions</i>	<i>Number of questions to be answered</i>	<i>Suggested times (minutes)</i>
Writing Task 1	1	30
Writing Task 2	1	30
Multiple-choice questions	70	120

- Students are permitted to bring into the examination room: pens, pencils, highlighters, erasers, sharpeners, rulers and an English and/or bilingual dictionary.
- Students are NOT permitted to bring into the examination room: blank sheets of paper and/or correction fluid/tape.
- No calculator is allowed in this test.

Materials supplied

- Question book of 40 pages.
- Answer book for **both** Writing Task 1 and Writing Task 2.
- Answer page for multiple-choice questions on page 15 of the answer book.

Instructions

- Write your **student number** on the answer book.
- Write your **name** on the multiple-choice answer page on page 15 of the answer book.
- Follow the times suggested for each task.
- All written responses must be in English.

At the end of the test

- You may keep this question book.

Students are NOT permitted to bring mobile phones and/or any other unauthorised electronic devices into the examination room.

WRITING TASK 1

To be answered in the answer book in blue or black pen.
You are advised to allocate 30 minutes to this task.

Consider the information on these two pages.

Develop a piece of writing presenting the main information in the material.
You should **not** present an argument.

Your piece will be judged on:

- how well you organise and present your understanding of the material
- your ability to communicate the information effectively
- how clearly you express yourself.

Due to copyright restrictions,
this material is not supplied.

The popular Legend Cafe, Melbourne, 1959



Coffee plants

Arabica bean

- hard to grow
- good flavour
- 60–70% of coffee consumed

Robusta bean

- hardy plant
- bitter flavour
- high caffeine content

BEAN EXPORTERS 2015–2016 in millions of tonnes

TOP
5

Brazil	1.9
Vietnam	1.5
Colombia	0.68
Indonesia	0.48
Honduras	0.31

“EVERYTHING IS CHAOS HERE. THE SUSPENSE IS ALMOST UNBEARABLE. WE ARE REDUCED TO QUARTER RATIONS AND NO COFFEE. AND NOBODY CAN SOLDIER WITHOUT COFFEE.”

Diary entry of Ebenezer Gilpin,
Union cavalryman, American
Civil War, April 1865

COFFEE: HISTORY, CULTIVATION, TRADE

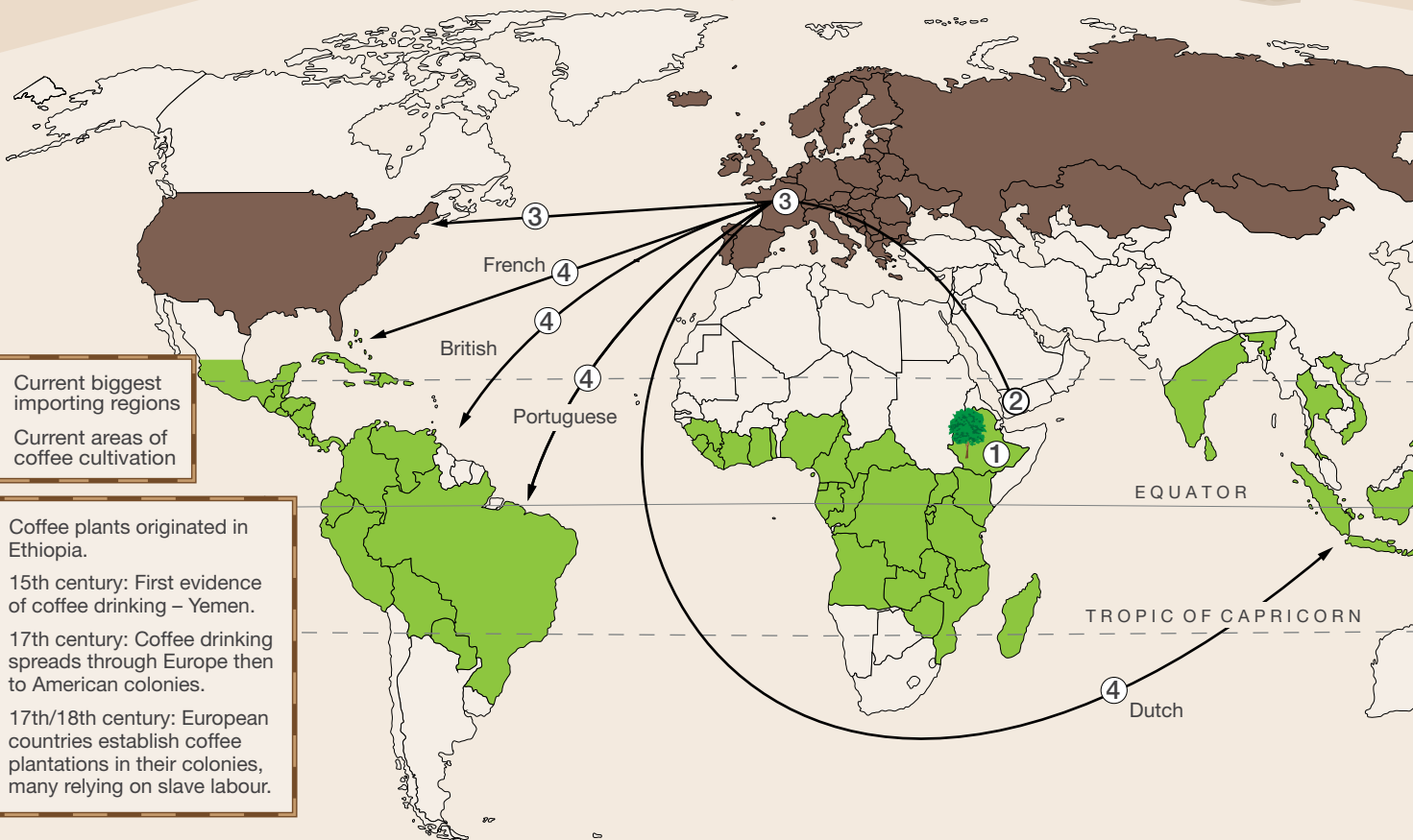

“THE FRESH SMELL OF COFFEE SOON WAFED THROUGH THE APARTMENT, THE SMELL THAT SEPARATES NIGHT FROM DAY.”

from a novel by Haruki Murakami

TEA AND COFFEE CONSUMPTION • AUSTRALIA

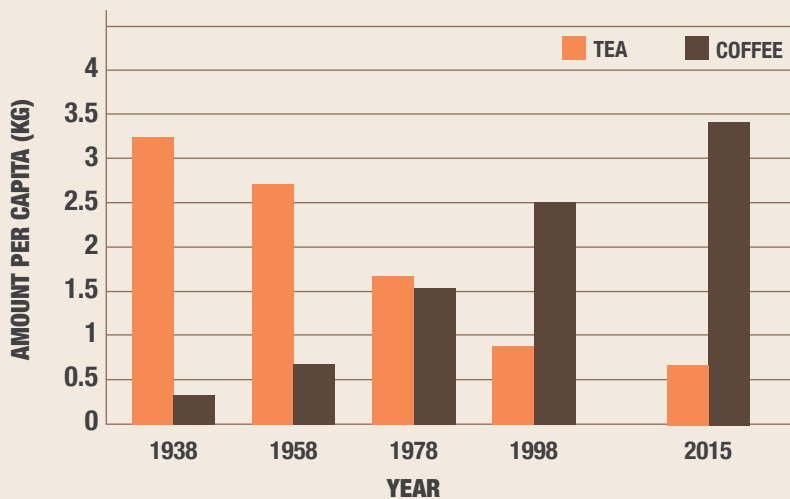

TOP 5 CONSUMERS 2015–2016 in millions of tonnes

European Union	2.5
USA	1.4
Brazil	1.2
Japan	0.46
Russia	0.23

ROASTING, GRINDING, TRANSFORMING

Due to copyright restrictions, this material is not supplied.



CAFFEINE IS FOUND IN ABOUT 60 PLANT SPECIES. IT IS A STIMULANT THAT ACTS ON THE BRAIN AND NERVOUS SYSTEM.

CAFFEINE CONTENT (approx. per serve)



20 mg
Hot chocolate



30 mg
Green tea



40 mg
Cola



50 mg
Black tea



80 mg
Energy drink



82 mg
Instant coffee



100 mg
Brewed coffee



100 mg
Shot of espresso

Coffee in Australia

1790	Coffee seedlings planted but Sydney climate unsuitable
1830s–1890s	Coffee palaces arise from Temperance Movement – coffee seen as alternative to ‘demon’ alcohol
1850s–1920s	Street coffee stalls in cities
1920s–1930s	Coffee lounges appear as part of jazz culture – first espressos served
1942–1945	American servicemen in Australia – coffee consumption doubles
1947	Instant coffee becomes available
1950s	European migrants inspire more people to drink coffee – Italian coffee machines imported
2012	Australian households spent \$1.1 billion on tea and coffee
2015	A third of Australian households have a coffee machine; 75% of the coffee that Australians drink is instant

WRITING TASK 2

*To be answered in the answer book in blue or black pen.
You are advised to allocate 30 minutes to this task.*

Consider the statements below.

Based on **one** or **more** of the statements, develop a piece of writing presenting your point of view.

Your piece of writing will be judged on:

- the extent to which you develop your point of view in a reasonable and convincing way
- how effectively you express yourself.

Most communication these days is just meaningless noise.

The ability to communicate meaningfully is what separates humans from other animals.

We are lucky to live in a world where there are many tools to help us communicate with one another.

The way we communicate determines the quality of our lives.

MULTIPLE-CHOICE QUESTIONS

*Answer this section in the GAT ANSWER BOOK.
Mark your answers on the Multiple-Choice Answer Page.*

You are advised to allocate 2 hours to this task.

Answer **all** questions in pencil.

Shade your answers on the multiple-choice answer page (page 15) of the answer book.
Choose the response that is **correct**, or that **best answers the question**.

A correct answer scores 1, an incorrect answer scores 0.

Marks will **not** be deducted for incorrect answers.

No marks will be given if more than one answer is completed for any question.

UNIT 1

Question 1

Due to copyright restrictions,
this material is not supplied.

©Mick Stevens/The New Yorker Collection/The Cartoon Bank

- 1 Which of the following does the cartoonist use to make his point?
- | | |
|-------------|------------------|
| A sarcasm | C exaggeration |
| B euphemism | D understatement |

UNIT 2

Questions 2 and 3

I wish our clever young poets would remember my homely definitions of prose and poetry; that is, prose = words in their best order; poetry = the best words in the best order.

Samuel Taylor Coleridge, poet

- 2 Which of the following best captures Coleridge's main point?
- A Poetry is superior to prose.
B Poetry and prose serve very different purposes.
C Poetry is a more flexible form of literary expression.
D The differences between prose and poetry are trivial.
- 3 What is Coleridge most likely trying to tell 'clever young poets'?
- A Their prose is more like poetry.
B Their poetry is more like prose.
C Prose and poetry are interchangeable.
D They need to follow literary traditions.

UNIT 3**Questions 4 – 6**

The following passage is from a short story about a young woman who has to move from Sydney to Australia's far north.

She said to her friends: 'I won't stay ... No, you probably don't, but I am.'

Due to copyright restrictions, this material is not supplied.
--

- 4 The young woman views moving north with
- A a few qualms.
 - B guarded optimism.
 - C a good deal of indifference.
 - D a strong desire for new experiences.
- 5 The young woman's move is seen by her friends as
- A regrettable.
 - B too sudden.
 - C unthinkable.
 - D an opportunity.
- 6 When in the north the young woman
- A finds that her life doesn't really change.
 - B adapts to her environment.
 - C struggles to adjust.
 - D refuses to change.

UNIT 4

Questions 7 – 9

When potatoes are fried in oil to make chips, toxic substances called *acrylamides* are produced.

Consider the following explanations regarding acrylamide production:

Explanation P – The higher the temperature of the oil, the more acrylamides are produced.









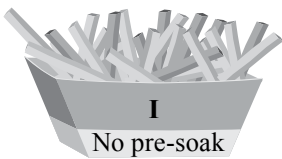

Explanation Q – Pre-soaking chips in water reduces the production of acrylamides.

Explanation R – Different potato varieties produce different amounts of acrylamides.

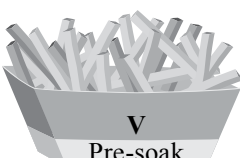
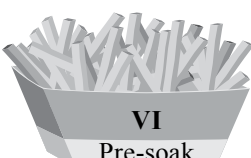
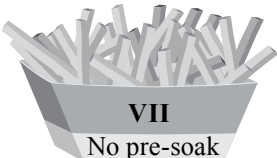
Trials were conducted to determine ways to minimise the amount of acrylamides produced.

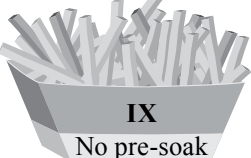
As shown in the table, the trials involved:

- cooking the chips at either 150 °C or 170 °C
- either pre-soaking the chips in water or not pre-soaking the chips
- using one of three types of potato (S, T or U) to make the chips.

	Type S	Type T	Type U
150 °C	 I No pre-soak	 II No pre-soak	 III No pre-soak
	 IV Pre-soak	 V Pre-soak	 VI Pre-soak
170 °C	 VII No pre-soak	 VIII No pre-soak	 IX No pre-soak
	 X Pre-soak	 XI Pre-soak	 XII Pre-soak

7 The results for which of the following trials could best be compared to test just **Explanation R**?

- A II, III and IV
- B II, VII and IX
- C IV, V and VI
- D V, XI and XII

8 Suppose for type S potatoes the amount of acrylamides produced, from least to most, was in trials IV, I, X, VII.

Which of **Explanation P** and **Explanation Q** would the results support?

- A **Explanation P** only
- B **Explanation Q** only
- C both **Explanation P** and **Explanation Q**
- D neither **Explanation P** nor **Explanation Q**

9 Suppose this graph shows the amount of acrylamides produced in trials I, II, V, VI, VII and XII.

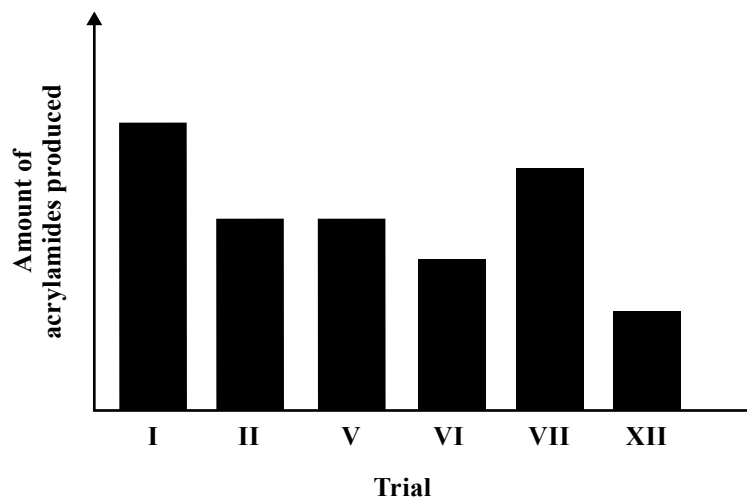

Which of **Explanation P** and **Explanation Q** do the results support?

- A just **Explanation P**
- B just **Explanation Q**
- C both **Explanation P** and **Explanation Q**
- D neither **Explanation P** nor **Explanation Q**

UNIT 5

Questions 10 – 12

The following diagram shows the flow of energy – from source to consumption – for Australia in 2012–2013. Households and industries use some forms of primary energy (energy gained directly from a natural resource) but energy resources are more commonly transformed into electricity or refined to create products such as petrol, diesel and aviation fuel.

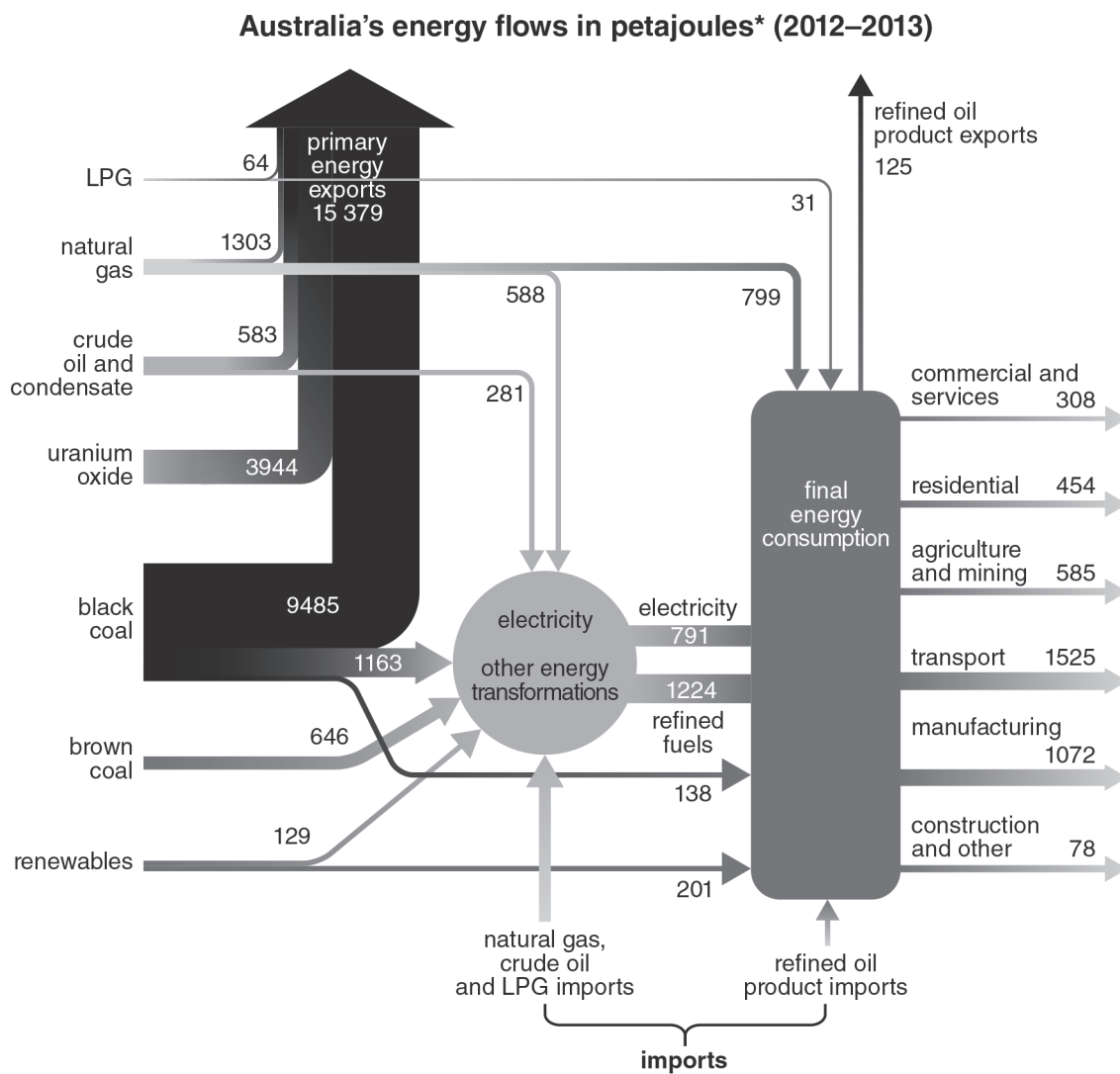

*Petajoule: a very large unit of energy

- 10 Which of the following energy sources is **not** exported by Australia?
 A LPG
 B crude oil
 C natural gas
 D brown coal
- 11 What does the diagram tell us about Australia's energy exports?
 A Only a small component is refined.
 B They are small by world standards.
 C The biggest component is uranium oxide.
 D Most are refined products.
- 12 In Australia, which one of the following resources is **not** used directly by final energy consumers?
 A renewable energy
 B brown coal
 C black coal
 D LPG

UNIT 6

Questions 13 and 14

He is a self-made man and worships his creator.

John Bright

- 13 Bright is most likely suggesting that the target of his remark is
 A uncultured.
 B patronising.
 C self-important.
 D self-conscious.

Her only flair is in her nostrils.

Pauline Kael

- 14 Kael is most likely suggesting that the target of her remark is
 A vain.
 B uninspiring.
 C unaffected.
 D simple-minded.

UNIT 7

Questions 15 – 18

At the start of every year at Parkview Primary School, each family is asked to select at least one of three maintenance activities (building, gardening and painting) in which to participate.

In the figure below, the seven shapes $\square \bigcirc \triangle \bullet + \heartsuit \text{pentagon}$ represent the number of families that selected each of the activities in any given year.

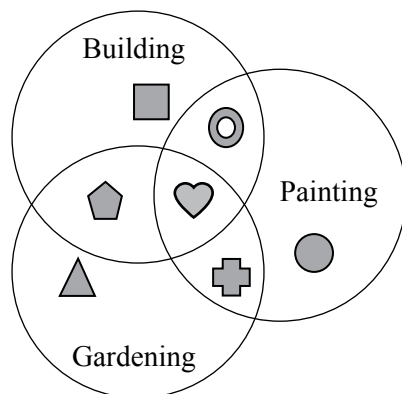

15 The number of families that selected gardening includes the numbers represented by

- A $+ \heartsuit$ and \heartsuit but not pentagon .
- B \triangle and pentagon but not \heartsuit .
- C pentagon and \bigcirc but not \square .
- D \heartsuit and $+$ but not \bigcirc .

16 In one year, two times as many families selected just two activities as the number of families that selected three activities.

Which of the following is true?

- A $\text{pentagon} + \bigcirc + + - 2 \heartsuit = 0$
- B $\text{pentagon} + 2 \bigcirc + + + 2 \heartsuit = 0$
- C $2 \text{pentagon} + 2 \bigcirc + 2 + - \heartsuit = 0$
- D $2 \text{pentagon} + 2 \bigcirc + 2 + + \heartsuit = 0$

Questions 17 and 18 refer to the following additional information.

In one year:

- 400 families selected building, 270 selected painting and 250 selected gardening
- 20 families selected both building and painting but not gardening
- 15 families selected both painting and gardening but not building
- 30 families selected both gardening and building but not painting.

17 Of the families that selected just one activity, how many **more** selected painting than gardening?

- A** 45
- B** 30
- C** 20
- D** 15

18 If 60 families chose all three activities, how many selected just gardening?

- A** 120
- B** 145
- C** 175
- D** 290

UNIT 8

Questions 19 – 22

The following passage is from a short story. Henry spends most of his time online or with his map collection.

Somewhere at the other end of the house – where the air was warmer, the colours brighter – his mother was sitting reading, or mixing batter for a Victoria sponge, or sewing her kitsch cross-stitch in Crayola colours that the craft market aficionados would pay decent money for. She was living.

‘Henry, it’s bad enough that I’m stuck here but you don’t have to be. You need to get out more. Live a little.’ All he heard was: ‘I wish you were more like your brother.’ 5

There were actually many similarities between his brother and him. Their love of travel was the greatest. Joel had spent all his adult life travelling, surfing the waves around the world, working for cash to fund the next adventure. Over the past few years, with the advent of GPS, Henry had set up an electronic map of where his brother had been. He’d collected real maps of all the places, too. He imagined himself well travelled, even if his mother snorted at that idea. 10

‘Google Earth is not the same as a holiday.’

He had tried to show her how he could be where Joel was. Virtually. But she just laughed and picked up one of his maps of Killarney Beach near Warrnambool. She opened it out, roughly pulling it from its neat folds. He winced as he watched her holding it open, stretching it so the delicate areas of the paper began to thin. 15

‘You can’t say you’ve been there just because you know the names of all the restaurants nearby.’ She nodded to the advertisements that outlined the map. ‘You actually need to go outside, get in a car and drive to these places, Henry.’ She slammed the map on his table, took one of his pens and drew a circle around the name of a local surf retailer. ‘And when you’re there you can get yourself a board and remember to have some fun.’ When she left he picked up the map and screwed it into a ball. You couldn’t have a marked map in your file. You just couldn’t. 20

19 The mother’s behaviour towards Henry suggests that she

- A** doesn’t accept him as he is.
- B** believes he has hidden talents.
- C** is excessively concerned for his welfare.
- D** is fascinated that he is so different from his brother.

20 Which combination (A–D) of true/false best describes Henry?

	obsessive	pedantic	lazy	erratic
A	true	true	false	false
B	false	true	false	true
C	true	false	true	false
D	false	false	true	true

21 A friend of the family was later asked: ‘Was there anything favourable about Henry’s mother?’

Based on the passage, which of the following would be the most accurate response?



- A ‘No. She was selfish and controlling.’
- B ‘At least she wanted him to be happy.’
- C ‘She tried to see the world through his eyes.’
- D ‘She had no idea about the nature of his activities.’

22 When the mother drew a circle on Henry’s map (line 22) she was most likely

- A wanting to ridicule him.
- B trying to share his interest in maps.
- C wanting to ruin his map.
- D unaware that she had damaged his map.

UNIT 9



Questions 23 – 27

Jordan purchased three types of beads: Hearts , Rounds  and Ovals .

Hearts come in packets of 5, Rounds in packets of 10 and Ovals in packets of 12.

To make necklaces, Jordan threads the beads onto string according to a pattern.

The first three possible necklaces using this pattern are shown in the table.

Necklaces	Number of Hearts	Number of beads
	1	5
	2	9
	3	13

- 23 If Jordan used 25 beads to make a necklace, how many Hearts were used?
- A 4
B 5
C 6
D 8
- 24 To make a necklace with a total of n beads, how many Rounds are needed?
- A $\frac{1}{4}n - 1$
B $\frac{1}{4}(n - 1)$
C $\frac{1}{2}n - 1$
D $\frac{1}{2}(n - 1)$
- 25 If Jordan used 30 Hearts to make a necklace, what was the total number of packets of beads of all types needed?
- A 6
B 12
C 15
D 18

- 26 Jordan made one necklace with 12 Rounds and another with 20 Rounds. How many packets of Ovals were needed?
- A 1
B 2
C 3
D 4
- 27 If Jordan used $z - 1$ Ovals to make a necklace, how many Hearts were used?
- A z
B $z - 1$
C $\frac{1}{2}z - 1$
D $z - 2$

UNIT 10

Questions 28 and 29

<p>I</p> <p>We have to live today by what truth we can get today and be ready tomorrow to call it falsehood.</p> <p style="text-align: right;"><i>William James</i></p>	<p>III</p> <p>Truth is more likely a weathered coat than an elegant suit.</p> <p style="text-align: right;"><i>Anon</i></p>
<p>II</p> <p>Truth never dies but lives a wretched life.</p> <p style="text-align: right;"><i>Yiddish proverb</i></p>	<p>IV</p> <p>A man is never more truthful than when he acknowledges himself a liar.</p> <p style="text-align: right;"><i>Mark Twain</i></p>

- 28 Quotation I suggests that
- A truth is relative.
B truth is non-existent.
C people are innately deceptive.
D people are not ready for the truth.
- 29 Which quotation is most clearly paradoxical?
- A I
B II
C III
D IV

UNIT 11

Questions 30 – 32

The erosion of desert sand dunes may be reduced by the growth of a plant called *Spinifex*.

In the figure, the dashed line (-----) shows the relationship between *Spinifex* area (the area of the dune it covers, % covered) and the age (years) of the *Spinifex* plants growing on the dune.

The other three lines in the figure show the relationship between *Spinifex* area and sand movement (units per hour) for each of three wind speeds (W). The three wind speeds are 10, 13 and 15 metres per second (m/s).

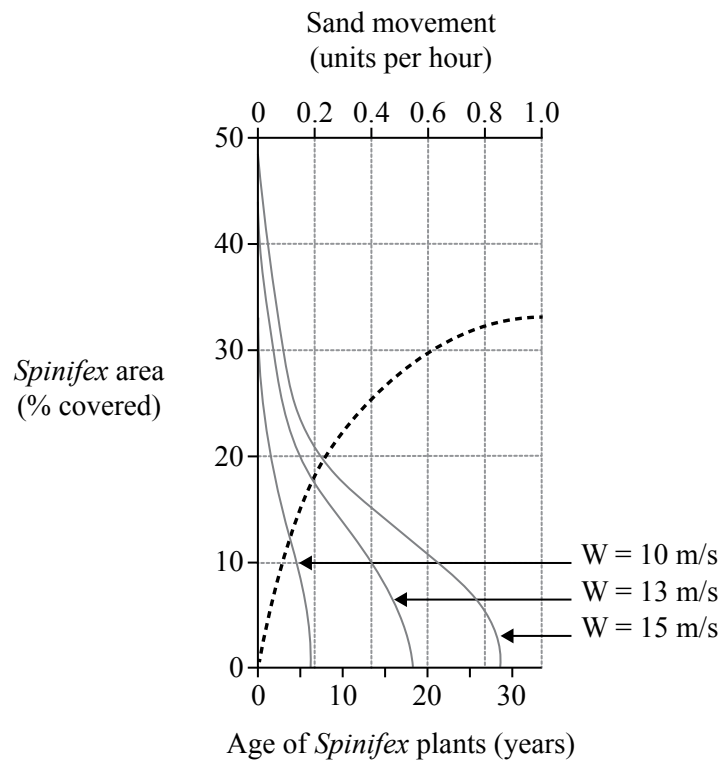

Assume that for a dune there is an equal number of *Spinifex* plants growing per square metre.

- 30 Which of the following is the best estimate of the age of *Spinifex* plants that cover 30% of a dune?
- A 5 years
 - B 10 years
 - C 15 years
 - D 20 years
- 31 The area of a dune covered by 15-year-old *Spinifex* plants is closest to
- A 5%.
 - B 15%.
 - C 27%.
 - D 33%.
- 32 When *Spinifex* plants cover 10% of a dune and wind speed is 13 m/s, sand movement is closest to
- A 0.2 units per hour.
 - B 0.4 units per hour.
 - C 0.6 units per hour.
 - D 0.8 units per hour.

UNIT 12

Questions 33 – 36

The following passage is from a book about friendship.

Due to copyright restrictions,
this material is not supplied.

5

10

- 33 In lines 1–3, friendship is portrayed as
- A gratifying and rewarding.
 - B protective and reassuring.
 - C baffling and often distressing.
 - D challenging and somewhat daunting.
- 34 The writer suggests that ‘devotees of pop psychology’ (line 8)
- A have no values.
 - B are hypocritical.
 - C hold conflicting values.
 - D are intolerant and judgmental.
- 35 In lines 12 and 13 the writer
- A contradicts himself.
 - B deliberately changes the subject.
 - C states his own subjective values as if they were objective truths.
 - D states objective truths as if they were his own subjective values.
- 36 The passage is best described as
- A reflective and meandering.
 - B instructive and opinionated.
 - C controversial and aggressive.
 - D dispassionate and sentimental.

UNIT 13

Questions 37 – 39

We Being Ghosts

Too many of my friends

...

Constantly.

Due to copyright restrictions,
this material is not supplied.

Clive James

- 37 When the poet asks, ‘How am I still upright?’ (line 3) he is
- A panicking and emotional.
 - B expressing confusion about his situation.
 - C using a rhetorical question to hide his vanity.
 - D using wry humour to conceal his anxiety.
- 38 Lines 9–11 suggest the poet
- A was misled by friends.
 - B had unnatural levels of energy.
 - C was distracted by his busy life.
 - D took his productivity for granted.
- 39 Overall, the poet comes across as
- A resigned and despairing.
 - B flippant and unforgiving.
 - C coldly analytical.
 - D harshly evasive.

UNIT 14

Questions 40 and 41

In this unit,

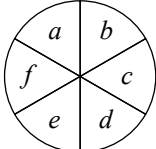
- **P** is of the form 

- the letters **a-f** represent integers (positive, negative or zero; ... -2, -1, 0, 1, 2, ...)

- ★, ● and ■ represent processes such that:

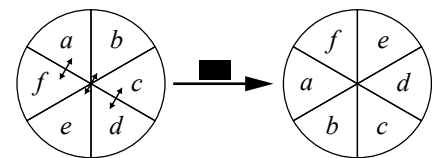
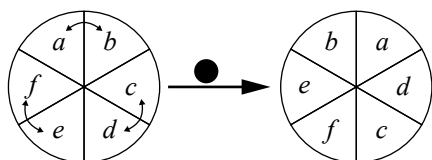
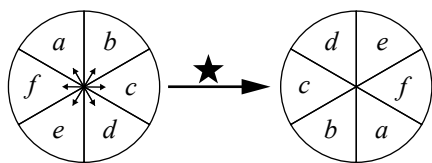

- multiple processes are applied in order from left to right.

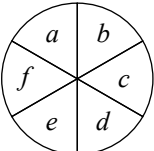
For example,  $\xrightarrow{\bullet \blacksquare}$ is the same as

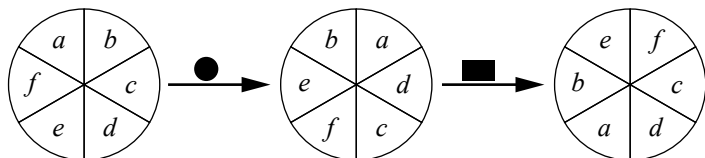

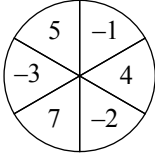
40 If $P =$ , what is the result of applying the processes ●★ to P?

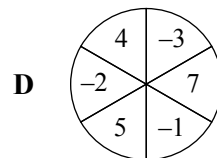
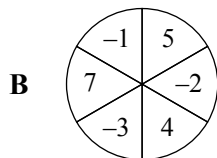
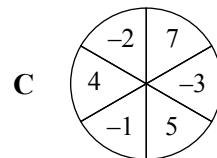
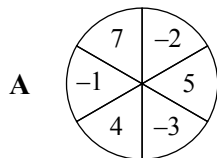

41 Consider the following multiple processes:

I: ★■ = ■★

II: ■● = ●■

Which of I and II is always true for any P?

- A just I
- B just II
- C both I and II
- D neither I nor II

UNIT 15

Questions 42 – 46

In a study of the effect of diet on a particular blood protein, two groups of 40 participants were placed on either Diet I or Diet II.

After three months, the blood-protein level (measured in milligrams per decilitre of blood, mg/dL) of each participant was recorded in the chart below.

Diet I participants								Diet II participants											
						6	0	10											
				9	8	4	1	11	1										
9	9	8	8	7	6	6	3	12	0	3									
9	9	8	7	7	5	2	0	13	0	2	6								
		9	6	5	3	1	0	14	1	2	5	5							
			5	3	3	2	1	15	0	3	6	8	8	9					
			6	4	1	0		16	1	4	4	7	7	9	9				
						5	4	17	3	3	7	8	8	9					
							1	18	0	3	4	7	7						
								19	1	5	6	6							
								20	0	3									

In the chart, the blood-protein level of each participant is represented by two numbers: the bold two-digit number in the central column represents the hundreds and tens, and the single-digit numbers to either side represent the units.

For example, the grey shaded box for the participant on Diet II could be written as 12 | 0 and represents 120 mg/dL. The grey shaded box for the participant on Diet I could be written as 16 | 4 and represents 164 mg/dL.

Assume that:

- at the start of the study, all participants had a blood-protein level between 161 and 190 mg/dL (inclusive)
- any change in the blood-protein level was a direct result of the diet followed during the study.

42 How many participants recorded a blood-protein level of 164 mg/dL after three months?

- A 1
- B 2
- C 3
- D 4

- 43 What is the maximum number of participants whose blood-protein level **must** have risen as a result of Diet II?
- A 7
 - B 6
 - C 5
 - D 0
- 44 Which of the following statements is best supported?
Compared with Diet I, Diet II is
- A less likely to cause a reduction in the blood-protein level.
 - B more likely to cause a reduction in the blood-protein level.
 - C less likely to cause a change in the blood-protein level.
 - D more likely to cause a change in the blood-protein level.
- 45 The participant whose blood-protein level is represented by 16 | 6 in the chart
- A could have had an unchanged blood-protein level.
 - B must have had a reduced blood-protein level.
 - C must have had an increased blood-protein level.
 - D must have had either a reduced or an increased blood-protein level.
- 46 What was the greatest possible reduction in the blood-protein level recorded for a participant in this study?
- A 81 mg/dL
 - B 90 mg/dL
 - C 92 mg/dL
 - D 103 mg/dL

UNIT 16

Questions 47 – 50

The graph below shows the results of a 2014 ‘Global Attitudes Survey’ in which people from 40 countries (not including Australia) were asked to rate their wellbeing by placing themselves on a ‘ladder of life’ with a scale from 1 to 10. The top of the ladder represented the best possible life and the bottom, the worst possible life. Respondents were asked to nominate where on the ladder they stood at that time.

Note:

- The vertical axis on the graph shows the percentage of survey respondents who selected 7, 8, 9 or 10 (only) on the ‘ladder of life’.
- The horizontal axis on the graph shows Gross Domestic Product (GDP) per capita. This refers to the market value of all goods and services produced within a country in a year, divided by the number of people in that country for the same year. It is accepted as a measure of a country’s economic performance.

Life satisfaction vs GDP per capita

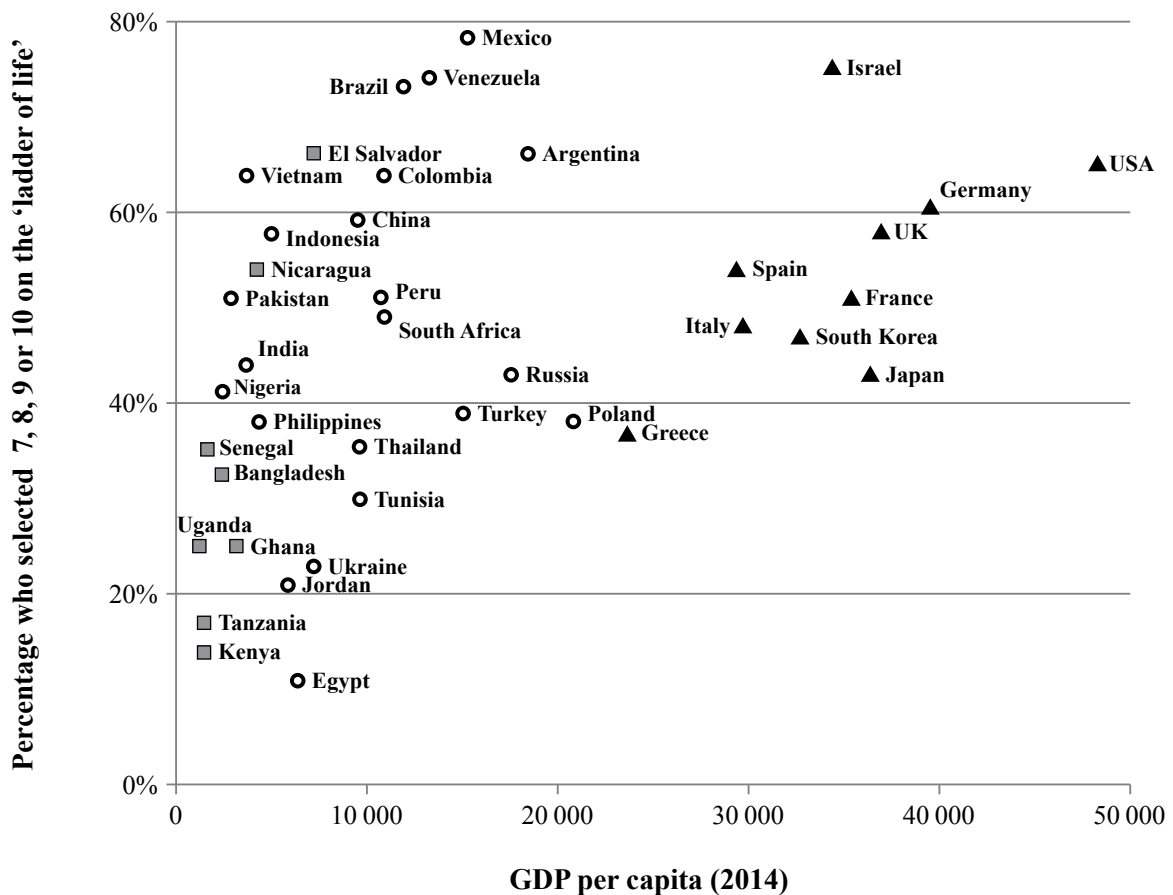

- ▲ Advanced economies
- Emerging economies
- Developing economies

Use the following to answer each question:

- A** The graph shows the statement to be true.
- B** The graph shows the statement to be false.
- C** The graph suggests that the statement could be true, but not conclusively.
- D** The graph is not relevant to the statement.

47 Advanced economies have the happiest citizens.

48 People in developing economies are more likely to report lower life satisfaction than people in advanced economies.

49 People who prioritise non-material aspects of life have the highest life satisfaction.

50 Israel's high GDP per capita is the main reason for the high life satisfaction of its citizens.

UNIT 17

Questions 51 – 53

Carrageenans are substances that are extracted from seaweeds, and are often used in the food industry. Olivia is trying to separate three types of powdered carrageenans: *kappa*, *iota* and *lambda*, from a mixture of the three. She finds a table that shows whether these carrageenans are soluble (will dissolve) in the following four solvents: cold water, hot sugar solution, cold milk, and brine (salt solution). The table also shows which carrageenans form a gel in water in the presence of either potassium ions or calcium ions.

Carrageenan type	Soluble in cold water	Soluble in hot sugar solution	Soluble in cold milk	Soluble in brine	Forms a gel in water in the presence of	
					potassium ions	calcium ions
<i>kappa</i>	no	yes	no	no	yes	no
<i>iota</i>	no	no	no	yes	no	yes
<i>lambda</i>	yes	yes	yes	yes	no	no

In order to separate the three carrageenans, Olivia adds a solvent to the mixture. She then pours this onto filter paper to separate the soluble from insoluble material. Insoluble material is left behind on the filter paper, while soluble material passes, with the solvent, through the filter paper and into the flask to form a *filtrate*. This is shown in Figure 1.

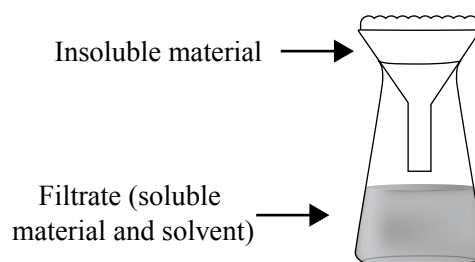
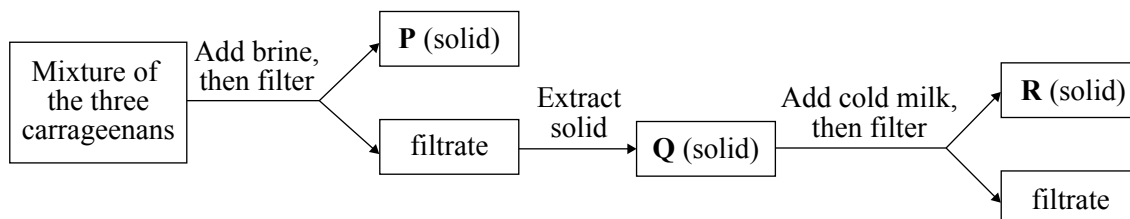

Figure 1

Note: soluble material in the filtrate can be extracted as a solid by boiling the filtrate to evaporate the solvent.

51 Suppose Olivia used the process shown below.



Solid **Q** contains which carrageenans?

- A just *iota*
- B just *kappa*
- C both *iota* and *kappa*
- D both *iota* and *lambda*

Questions 52 and 53 refer to the following additional information.

Suppose Olivia used the process shown below.

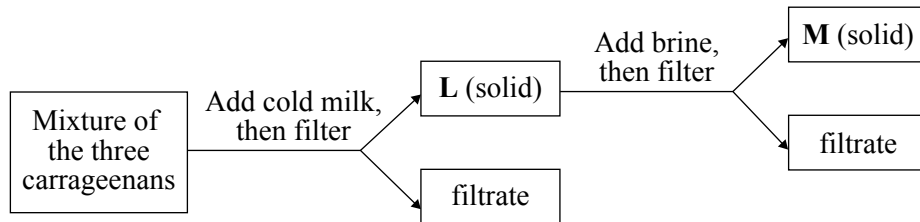

- 52 Which of the following best describes Solids **L** and **M**?
- A Solid **L** and Solid **M** are both mixtures.
 - B Solid **L** and Solid **M** are both single substances.
 - C Solid **L** is a single substance and Solid **M** is a mixture.
 - D Solid **L** is a mixture and Solid **M** is a single substance.
- 53 Suppose the process shown in the figure above was modified so that the brine was added **before** the cold milk instead of after.
- Which of the following would be true?
- A Solid **M** would be the same and Solid **L** would be different.
 - B Solid **L** would be the same and Solid **M** would be different.
 - C Each of Solid **L** and Solid **M** would be the same.
 - D Each of Solid **L** and Solid **M** would be different.

UNIT 18

Questions 54 – 56

Time-lapses are used in film-making to make slow-moving objects appear to move faster. A time-lapse is composed of a sequence of images, or *frames*, taken of a moving object at regular time intervals. When the frames are played back at a rate faster than they were taken, the object appears to move faster.

The total number of frames (**N**) required in any time-lapse depends on the intended final length of the time-lapse (**L**, in seconds, s) and the play-back rate (**R**, in frames per second, F/s):

$$\mathbf{N} = \mathbf{L} \times \mathbf{R}$$

In a *standard* time-lapse, **R** = 30 F/s. For example, 450 frames are required to make a standard 15-second time-lapse ($15 \times 30 = 450$).

The time interval (**I**, in seconds) between taking each frame depends on the actual time (**T**, in seconds) that is to be represented in the time-lapse and the total number of frames (**N**):

$$\mathbf{I} = \frac{\mathbf{T}}{\mathbf{N}}$$

For example, if a standard 15-second time-lapse of a moving object (where, from above, **N** = 450) represents 90 minutes (5400 s) of actual time, the frames must be taken at a rate of one frame every 12 seconds ($5400 \div 450 = 12$ s).

The following table gives the speed of four moving objects. Assume that these objects move at a constant rate.

Object	Speed (km/h)
Pedestrian	5
Tram	15
Cyclist	25
Car	50

- 54** Kim creates a time-lapse in which cars appear to move at 100 km/h.
How could Kim make the cars appear to travel at 120 km/h?
- A** shorten the time-lapse by increasing the rate at which frames are played back
 - B** shorten the time-lapse by decreasing the rate at which frames are played back
 - C** lengthen the time-lapse by increasing the rate at which frames are played back
 - D** lengthen the time-lapse by decreasing the rate at which frames are played back
- 55** A standard 20-second time-lapse was created with frames taken at intervals of 3 seconds by a camera attached to a tram.
What distance was travelled by the tram?
- A** 2.5 km
 - B** 5.0 km
 - C** 7.5 km
 - D** 9.0 km
- 56** What is **I** for a standard 10-second time-lapse of a pedestrian walking for a distance of 500 metres?
- A** 1.0 second
 - B** 1.2 seconds
 - C** 1.5 seconds
 - D** 1.8 seconds

UNIT 19

Questions 57 – 60

The following is a transcript of an interview with a legal expert in which she discusses a well-known Australian court case.

Legal expert: The case of Mr Smith ... is the man in the dock?’

Due to copyright restrictions,
this material is not supplied.

- 57 In the original court case, what was the purpose of showing police the CCTV photographs?
- A Only the police knew how to interpret the images correctly.
 - B It was imperative that the police discover who was in the photographs.
 - C The defendant’s case would have been weakened without the police testimony.
 - D The prosecution’s case would have been weakened without the police testimony.
- 58 The appeal to the High Court was most likely made by the
- A jury.
 - B police.
 - C defence team.
 - D prosecution team.

- 59** According to the High Court decision, the identification of the man in the photographs should have been made by the
- A** jury alone.
 - B** judge alone.
 - C** jury and judge.
 - D** jury and police.
-
- 60** From the information provided in the transcript, which of the following is most likely to have occurred after the High Court's decision?
- A** Mr Smith would be retried and the jury would not be shown the CCTV photographs.
 - B** Mr Smith would be retried and the jury instructed to interpret the CCTV photographs.
 - C** Mr Smith would be retried and the jury instructed to consider the police interpretation of the CCTV photographs.
 - D** In all future cases the police would automatically be asked for their interpretations of CCTV photographs.

UNIT 20

Questions 61 – 63

Sue is using a computer to make an eight-page spelling book for her younger brother. Each page will have one word: *Ant*, *Bee*, *Cat*, *Dog*, *Eel*, *Fish*, *Goat* or *Horse*. In the finished book, the words will appear upright and in alphabetical order, one word per page.

Sue inserts the words into the eight positions (I to VIII) of the template (shown opposite), so that four words will print onto each side of a single sheet of paper with position VI on the back of position I.

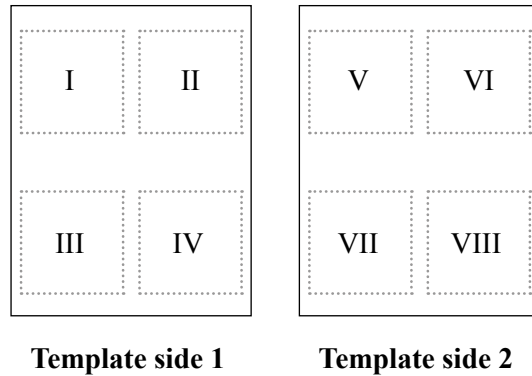

After printing, she makes two folds (1st and 2nd), then cuts along the top of the book to allow the pages to open and binds the book with metal rings (shown below).

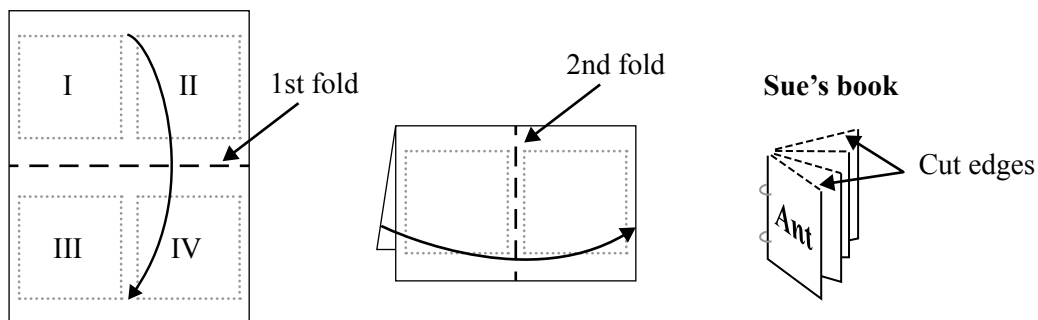

61 Which of the following insertions would cause Sue's book to print incorrectly?

- i inserting *Goat* into position IV
 - ii inserting *Horse* into position VII
- A i only
 B ii only
 C both i and ii
 D neither i nor ii

62 In what position of the template should Sue insert the word *Dog*?

- A IV
- B V
- C VI
- D VII

63 Which of the following should be Template side 1?

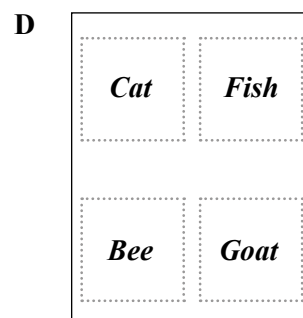
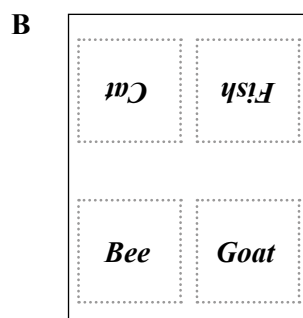
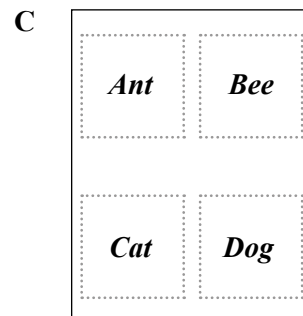
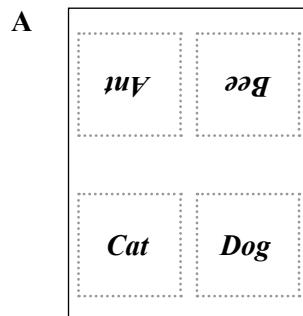

UNIT 21

Questions 64 – 67

Paint is composed of *solvents* and *solids*. Solvents are liquids that enable wet paint to be applied by a brush. After application, the solvents evaporate to leave just dry paint – the solids. The volume of solids (V) is measured as a percentage (%) of the volume of wet paint.

For any paint, the *wet film build* (W) is the thickness (in micrometres, μm) of a single freshly applied coat of paint. The *dry film build* (D) is the thickness (μm) of a single coat of paint that has completely dried. The *spreading rate* (S) is the area covered by 1 litre of paint (in square metres per litre, m^2/L). These paint properties are related according to the following equations:

$$D = \frac{V \times 10}{S} \qquad V = \frac{D \times 100}{W}$$

The table gives these properties for four brands of interior house paint. Some values are missing.

Brand of paint	V (%)	W (μm)	D (μm)	S (m^2/L)	Cost (\$) per 4-litre tin
Perfect Finish	70.0	250	?	4.0	60.00
Quality Colour	50.0	200	100	5.0	60.00
Reno's Dream	62.5	200	125	5.0	?
U-Paint Well	82.0	?	328	?	70.00

Assume that:

- paints can only be purchased in full 4-litre tins
- the paint properties refer to paint applied under identical conditions
- a satisfactorily painted interior wall requires a **total** thickness of dry paint of at least $260 \mu\text{m}$.

64 Compared with U-Paint Well, how many coats of Reno's Dream are required to satisfactorily paint an interior wall?

- A two more
- B one more
- C no more
- D one less

65 What is the minimum cost to buy sufficient Perfect Finish to satisfactorily paint 30 m² of interior wall?

- A \$160
- B \$200
- C \$240
- D \$260

66 What is the relationship between S and W?

A $S = \frac{W}{100}$

B $S = \frac{100}{W}$

C $S = \frac{W}{1000}$

D $S = \frac{1000}{W}$

67 Joan calculated that, compared with Quality Colour, it would cost her \$60 less to satisfactorily paint 15 m² of interior wall with Reno's Dream.

How much does a 4-litre tin of Reno's Dream cost?

- A \$30
- B \$40
- C \$50
- D \$60

UNIT 22

Questions 68 – 70

*The paintings on the opposite page are by French painter Edouard Vuillard (1868–1940).
Vuillard's widowed mother supported her family by working from home as a corset-maker and dressmaker.*

- 68** Painting 1 presents the women as
- A** dejected and lifeless.
 - B** self-conscious and awkward.
 - C** collaborative and social.
 - D** industrious and absorbed.
- 69** In painting 2, Madame Vuillard (the figure on the right) is presented as
- A** elegant.
 - B** passive.
 - C** formidable.
 - D** compassionate.
- 70** Which one of the following applies to both paintings?
- A** Domesticity is idealised.
 - B** Domesticity is portrayed in an unsentimental way.
 - C** Familiar spaces are rendered strange and remote.
 - D** The women are disconnected from their environment.



Painting 1: *The Flowered Dress (1891)*



Painting 2: *The Dressmaking Studio of Madame Vuillard (1892)*

GAT 2017 source references

Mick Stevens, *New Yorker*, 15 March 2010.

Alexander McCall Smith, 'Far North', *Heavenly Date and Other Flirtations*, Canongate, Edinburgh, 2003.

Vicky Daddo, 'Bakerloo, Central, Circle, District', *The Big Issue*, No. 466, 2014.

Andrew M. Greeley, *The Friendship Game*, Doubleday & Company, New York, 1970. Used by permission of Doubleday, an imprint of the Knopf Doubleday Publishing Group, a division of Penguin Random House LLC. All rights reserved.

Clive James, 'We Being Ghosts' in Peter Rose (ed.), *The Best Australian Poems 2008*, Scribe, Melbourne, 2008.

Pew Research Centre, October 2014, 'People in emerging markets catch up to advanced economies in life satisfaction'. <http://www.pewglobal.org/files/2014/10/Pew-Research-Center-Life-Satisfaction-Report-FINAL-October-30-2014.pdf>

Law Report, Radio National, 28 August 2007.

Lygon Street trader Fab Succi, photograph by Joe Armao, Fairfax Syndication.

The Legend Cafe, Melbourne, 1959, courtesy of Sumiko McDonald.

Haruki Murakami, *Colorless Tsukuru Tazaki and His Years of Pilgrimage*, Vintage Books, New York, 2015.

Ebenezer Gilpin, <http://www.npr.org/sections/thesalt/2016/07/25/485227943/if-war-is-hell-then-coffee-has-offered-u-s-soldiers-some-salvation>