



Victorian Certificate of Education 2009

General Achievement Test

Thursday 11 June 2009

Reading time: 10.00 am to 10.15 am (15 minutes)

Writing time: 10.15 am to 1.15 pm (3 hours)

QUESTION BOOK

Structure of book

<i>Type of questions</i>	<i>Number of questions to be answered</i>	<i>Suggested times (minutes)</i>	<i>Suggested time allocation</i>
Writing Task 1	1	30	10.15 – 10.45
Writing Task 2	1	30	10.45 – 11.15
Multiple-choice questions	70	120	11.15 – 1.15

- Students are permitted to bring into the examination room: pens, pencils, highlighters, erasers, sharpeners, rulers, and an English and/or bilingual dictionary.
- Students are NOT permitted to bring into the examination room: blank sheets of paper and/or white out liquid/tape.
- No calculator is allowed in this examination.

Materials supplied

- Question book of 36 pages.
- Answer book for **both** Writing Task 1 and Writing Task 2.
- Answer page for multiple-choice questions on page 15 of the answer book.

Instructions

- Write your **student number** and **student name** on the answer book.
- Write your **student name** on the answer page for multiple-choice questions on page 15 of the answer book.
- Follow the times suggested for each task.
- You may complete tasks in any order and you may return to any task at any time.
- Do not waste time on one particular multiple-choice question. If you find a question very difficult, return to it later.
- Answer all questions.
- All written responses must be in English.

At the end of the test

- You may keep this question book.

Students are NOT permitted to bring mobile phones and/or any other unauthorised electronic devices into the examination room.

WRITING TASK 1

To be answered in the answer book in pen, not pencil.
You are advised to allocate 30 minutes to this task.

Consider the information on these two pages.
Develop a piece of writing presenting the main information in the material.
You should **not** present an argument.

Your piece will be judged on:

- how well you organise and present your understanding of the material,
- your ability to communicate the information effectively, and
- how clearly you express yourself.

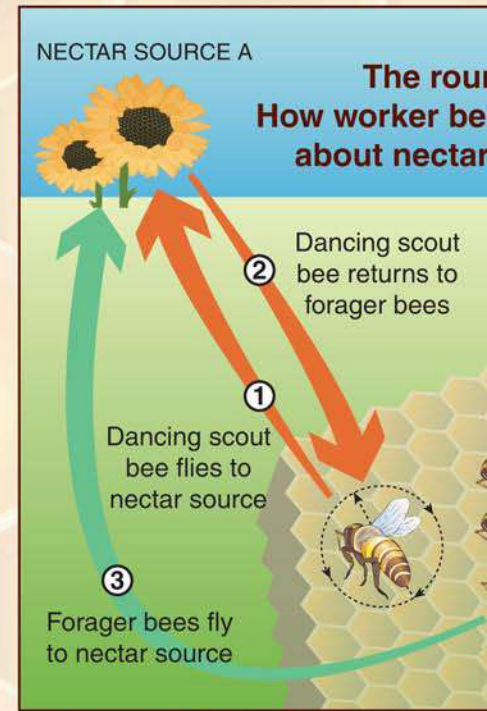

A commercial beehive

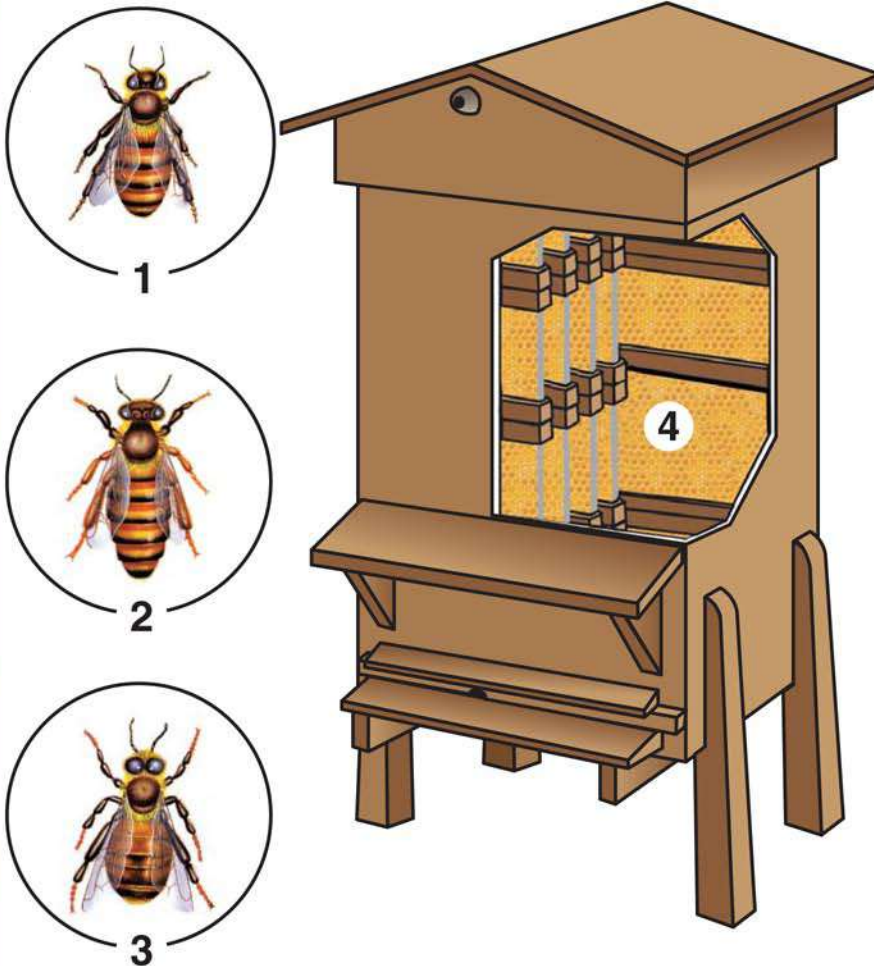

Key for the beehive

1. worker bee	sterile female; number in hive = 10 000–60 000; includes 'forager bee' and 'dancing scout'
2. queen bee	only reproductive female in the colony; only function is to lay eggs; number in hive = 1
3. drone bee	male whose only function is to contribute to reproduction; number in hive = 100–500
4. brood chamber	houses queen; eggs, larvae, pupae and reserves of pollen and honey found in the honeycomb cells

Function and lifespan

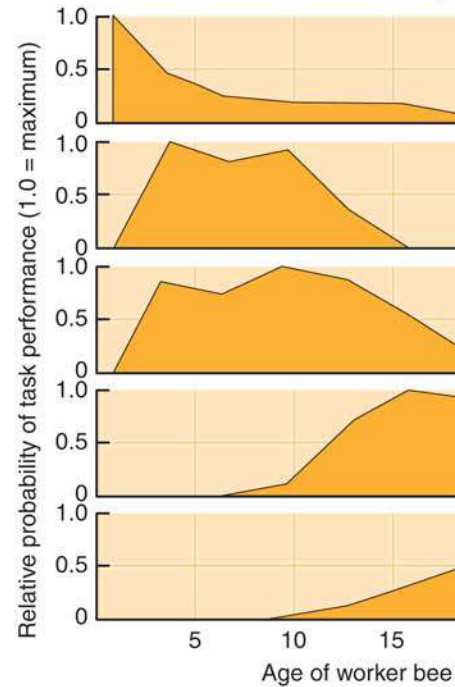

A year in

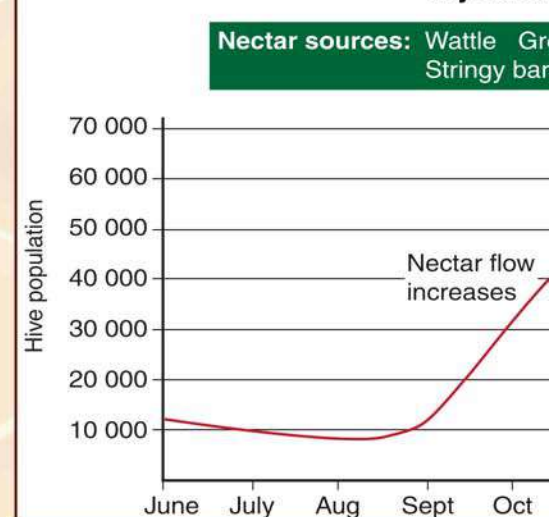

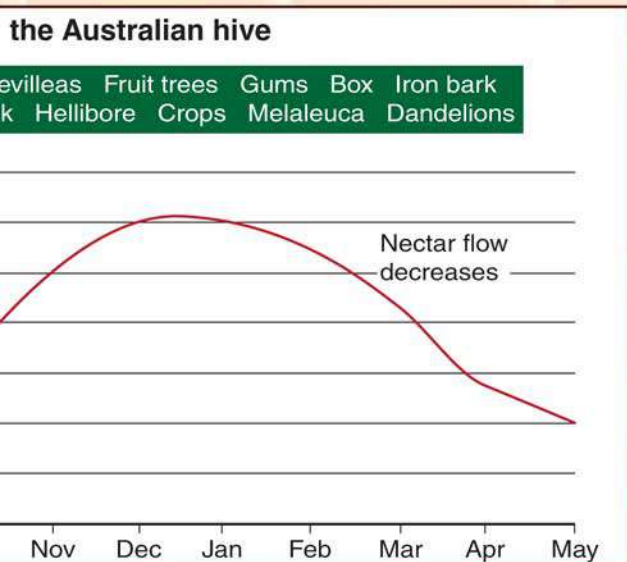
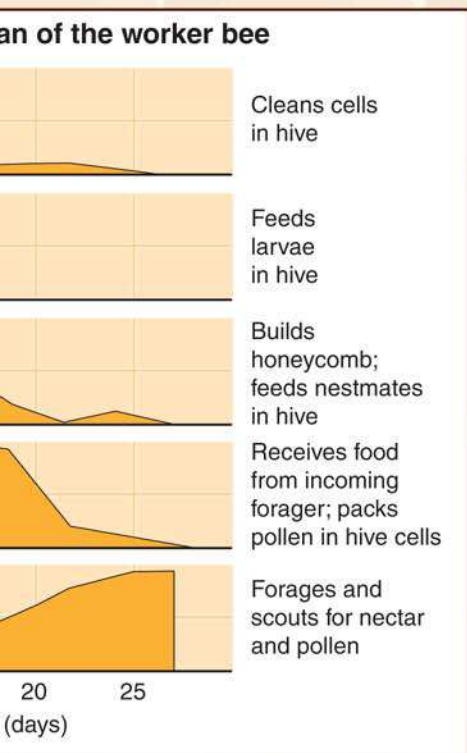
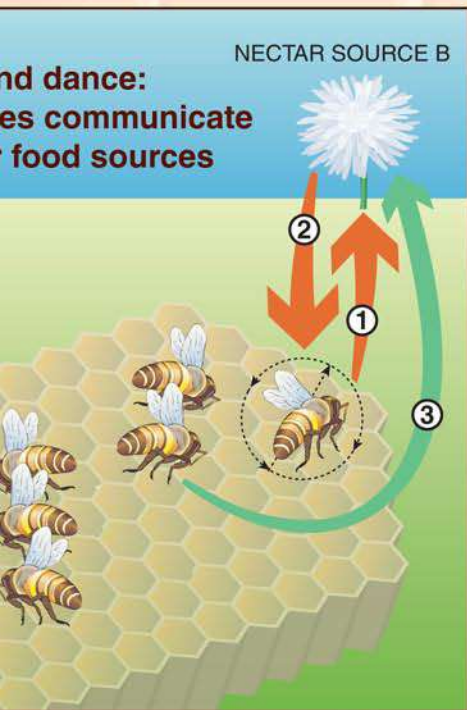

Bees and humans

Bee symbolism

Ancient Egypt
1100 BC

Napoleon's chosen
symbol 1804

US Naval Construction
Battalion 1942,
World War 2

• Hard work • Determination • Fertility • Industry • Community • Royalty

Bee product produced in hive	Human use	Bee sayings
Honey	Food, mead (honey wine), medication, cosmetic	• as busy as a bee
Beeswax	Candles, soap, cosmetics, sealant, polish, pharmaceutical, food coating	• one bee is no bee
Royal Jelly	Traditional medicine, cosmetic, dietary supplement	• making a beeline
Bee Venom	Traditional medicine	• you catch more bees with honey than with vinegar
Bee Pollen	Traditional medicine; pollination of plants associated with collection of pollen	

Reliance on bees

Some of the most valuable fruit, vegetable, nut and field crops depend on insect pollination, which allows germination of plants.

	Crop value in billions 2006 *	Percentage pollinated by bees	Percentage of crop pollinated by ...		
			Bees	Other insects	Other
Soybeans	\$19.7	5%			
Cotton	5.2	16			
Grapes	3.2	1			
Almonds	2.2	100			
Apples	2.1	90			
Oranges	1.8	27			
Strawberries	1.5	2			
Peanuts	0.6	2			
Peaches	0.5	48			
Blueberries	0.5	90			

* Estimated worldwide figures only

- estimated annual gross value of Australian honey industry: \$65 million
- estimated annual value of pollination to the Australian economy: between \$100 million and \$1.7 billion

WRITING TASK 2

*To be answered in the answer book in pen, not pencil.
You are advised to allocate 30 minutes to this task.*

Consider the statements below.

Based on **one** or **more** of the statements, develop a piece of writing presenting your point of view.

Your piece of writing will be judged on:

- the extent to which you develop your point of view in a reasonable and convincing way, and
- how effectively you express yourself.

Material possessions do not bring contentment; they often bring dissatisfaction because we are always aware of what we don't possess.

Material possessions bring with them a sense of our achievements, and a sense of security. They are proof of our efforts to improve our lives.

It is our preoccupation with possessions that prevents us from living a free and noble life.

It is perfectly acceptable that our possessions bring us happiness and contentment. We should not be made to feel guilty about enjoying what we have.

MULTIPLE-CHOICE QUESTIONS

*Answer this section in the GAT ANSWER BOOK.
Mark your answers on the Multiple-Choice Answer Page.*

You are advised to allocate 2 hours to this task.

Choose the response that is **correct**, or that **best answers the question**, and shade the square on the answer page for multiple-choice questions according to the instructions on that page.

A correct answer is worth 1 mark, an incorrect answer is worth 0 marks. No marks will be given if more than one answer is shown for any question. Marks will **not** be deducted for incorrect answers.

UNIT 1

Question 1



URBAN RELAXATION

- 1 This cartoon is about
- A ambition.
 - B endurance.
 - C indulgence.
 - D misconception.

UNIT 2

Question 2

Around his neck, Tom wears a carved octopus pendant hanging from a cord (Figure 1). The pendant is darker on one side than on the other (Figures 2a and 2b). The clip can be attached to the pendant in four additional places (Figure 3).

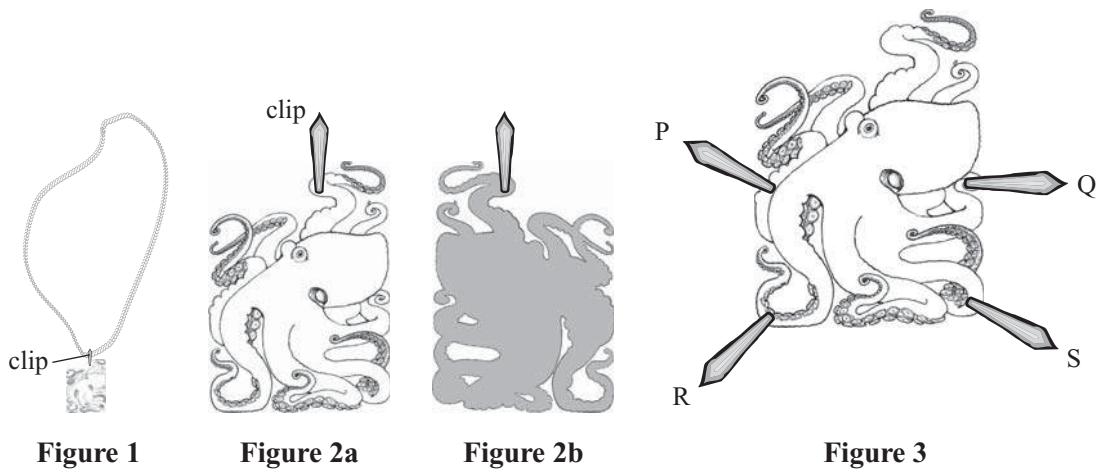

- 2 Susan puts on the octopus pendant. Tom is facing her and sees it as shown in Figure 4.
Susan has put the clip in position

- A P.
- B Q.
- C R.
- D S.



Figure 4

UNIT 3

Questions 3 – 6

Cold reading is a group of techniques used by fortune tellers and psychics to covertly discover details about a person. Cold readers commonly employ high probability guesses based on the subject's appearance (and refined on the basis of the subject's reactions) so as to emphasise and reinforce any chance connections the subject acknowledges while the reader quickly moves on from missed guesses. Before starting the actual reading, the reader will typically try to gain cooperation from the subject by saying something like: 'I often see images that are a bit unclear and which may sometimes mean more to you than to me; if you help, we can together uncover new things about you'. A crucial element in a convincing cold reading is a subject eager to make connections or reinterpret vague statements in any way that will help the reader appear to have specific intuitions and to have made specific predictions. While the reader will do most of the talking, it is the subject who provides the meaning.

The following are four common cold reading techniques:

Shot Gunning	This technique involves a series of very general claims some of which will be correct, or near correct, and the subjects' reactions are used to narrow the scope of the claims.
Fine Flattery	In this technique the reader asks the subjects to agree that they have some valuable characteristic or other.
Barnum Statements	This technique involves a statement that seems to be specific and personal but actually applies to most people.
The Rainbow Ruse	This technique involves statements that simultaneously describe the subject with a specific personality trait, as well as the opposite of that trait.

3 The following statement by a reader or psychic:

I sense that you are sometimes insecure, especially with people you don't know very well.

would be best described as an example of

- A Shot Gunning.
- B Fine Flattery.
- C Barnum Statements.
- D The Rainbow Ruse.

- 4 The following statement by a reader or psychic:

You are an independent person who accepts responsibility.

would be best described as an example of

- A Shot Gunning.
- B Fine Flattery.
- C Barnum Statements.
- D The Rainbow Ruse.

- 5 The following statement by a reader or psychic:

I would say that you are mostly shy and quiet, but when the mood strikes you, you can easily become the centre of attention.

would be best described as an example of

- A Shot Gunning.
- B Fine Flattery.
- C Barnum Statements.
- D The Rainbow Ruse.

- 6 Which of the cold reading techniques is **least** dependent on the subject making the meaning?

- A Shot Gunning
- B Fine Flattery
- C Barnum Statements
- D The Rainbow Ruse

UNIT 4

Questions 7 – 9

This diagram shows the marine fossil record of major groups of animals (e.g. Trilobita) during the last 680 million years. The width of the spindle record for a group is proportional to the number of species present at the time.

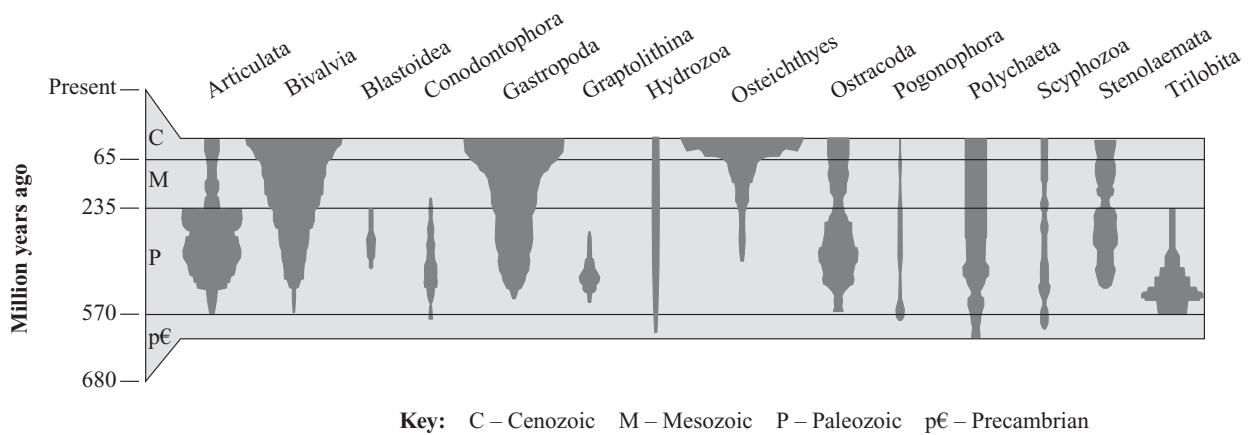

- 7 Which of the following groups had the most species 65 million years ago?
- A Articulata
 - B Gastropoda
 - C Osteichthyes
 - D Trilobita
- 8 At the end of the Paleozoic a mass extinction occurred.
- If there were 100 species of Articulata in existence just before this mass extinction, approximately how many survived?
- A 20
 - B 50
 - C 80
 - D There is insufficient information provided to answer this question.
- 9 In general, as the number of species of Trilobita decreased, the number of species of
- A Gastropoda decreased.
 - B Gastropoda increased.
 - C Osteichthyes decreased.
 - D Osteichthyes increased.

UNIT 5

Questions 10 – 11

One style of personalised number plates allows a mixture of letters and digits. The rules applying to this style of number plate are:

- both letters and digits must be used;
- the first symbol must be a letter, not a digit;
- the digits 1–9 are allowed, but not 0;
- a number plate can only have four, five or six symbols (letters and digits).

Note: This is the letter O and this is the digit 0.

10 How many of the following number plates are allowed under the rules?

A3B6C9

MY230

24TEE

XY4GEN

XXX

B4MA

- A** two
- B** three
- C** four
- D** five

11 Under the rules, how many different number plates can have only one letter and three digits?

- A** $9 \times 9 \times 9$
- B** $26 \times 10 \times 10 \times 10$
- C** $26 \times 9 \times 9 \times 9 \times 4$
- D** $26 \times 9 \times 9 \times 9$

UNIT 6

Questions 12 – 14

The following diagram is from a book discussing marketing techniques. It shows four aspects of promoting a product.

Due to copyright restriction,
this material is not supplied.

- 12 The diagram suggests that ‘branding’ occurs when consumers
- A adopt marketed messages.
 - B understand why marketing occurs.
 - C use marketed messages differently from how they were intended.
 - D provide feedback to marketers about their products and services.

- 13 Which one of the following sets of words best represents ‘marketing’ and ‘branding’, as presented in the diagram?

	Marketing	Branding
A	product development	product promotion
B	seeking consumer views	attempt to sell
C	product promotion	influence upon consumer
D	trial promotion	consumer feedback

- 14 Which of the following quotations best captures the meaning of ‘branding’?
- A ‘The customer is always right.’
 - B ‘Perception is reality.’
 - C ‘To be convinced requires proof.’
 - D ‘A product is more important than its press.’

UNIT 7

Questions 15 – 18

Figure 1 indicates that the toe of a ballet shoe, or pointe shoe, contains a small, hardened box called the *toe box*.

A toe box helps ballerinas to dance on their toes.

Figure 2 indicates the *strength* and *stiffness*, measured in both axial and vertical directions, of the toe boxes of five brands (I to V) of pointe shoe.

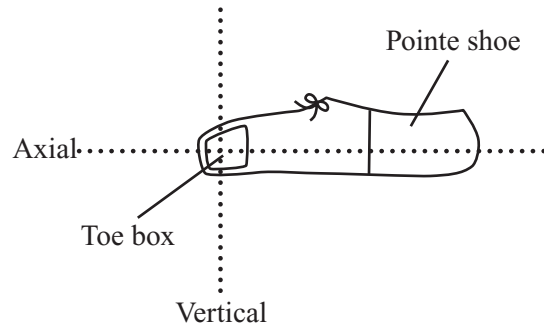

Figure 1

In this unit:

- strength relates to the maximum force that can be applied to a toe box before it breaks (in newtons, N).
- stiffness relates to resistance to change of shape of a toe box (in kilonewtons per metre, kN/m).

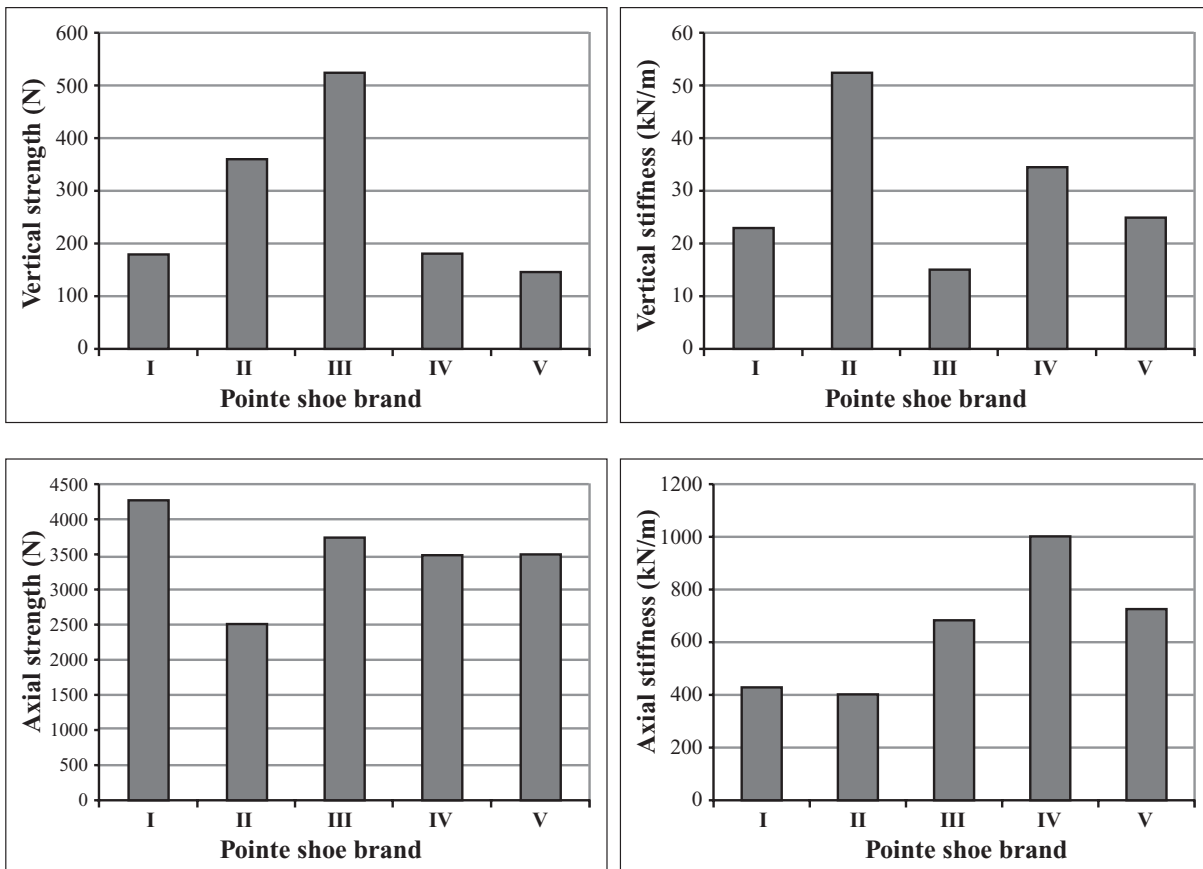

Figure 2

- 15 Jocelyn's pointe shoes need replacing, but she is unable to buy the brand **IV** shoes she prefers.
- Which other brand of pointe shoe would be most similar to brand **IV**?
- A **I**
 - B **II**
 - C **III**
 - D **V**
- 16 Wendy usually wears brand **V** pointe shoes. After she injured her toes, the doctor suggests she continues to use toe boxes but with minimum axial stiffness.
- Which shoe would best suit Wendy's usual preference and address the doctor's advice?
- A brand **I**
 - B brand **II**
 - C brand **III**
 - D brand **IV**
- 17 A toe box with a vertical stiffness less than 25 kN/m is most likely to also have
- A an axial stiffness less than 600 kN/m.
 - B an axial stiffness greater than 500 kN/m.
 - C a vertical strength less than 150 N.
 - D an axial strength greater than 3000 N.
- 18 The test results indicate that for all of the toe boxes,
- A axial strength is less than vertical strength.
 - B axial stiffness is less than vertical stiffness.
 - C axial stiffness is greater than vertical stiffness.
 - D axial strength is greater than axial stiffness.

UNIT 8

Questions 19 – 23

The following passage is from a novel. Ichthyology is the study of fish. Tip is an undergraduate university student.

Tip took a jar containing eight small warmouths from his basket and put them back on the shelf where they belonged. There were six rooms in the Department of Ichthyology, which was located beneath the museum, six brick-walled cells in the subterranean hive, each one a maze of metal shelving, fishes stacked floor to ceiling like bins of nails in a hardware store, 1.3 million dead fishes suspended in alcohol. A dozen or more tiny fish clustered together in small jars, single fish folded over in larger jars, huge fish alone in metal boxes. There were fish that had been recently discovered in the Amazon and a fish dating back as far as the 1700s. Put a jar in the wrong spot and you can pretty much say goodbye to it altogether. Tip followed the numbers with a librarian's precision, setting his basket on the floor so that he could handle the jar more carefully when he returned it to its proper location. Tip Doyle had a position of importance in the lab, even if his father didn't see it that way. Historically, the recataloguing of fishes was work for graduate students. That this job had come to Tip, a senior, was a sign of his seriousness and demonstrated his sense of responsibility.

'Does the country need another ichthyologist?' his father would have said had he been following Tip through his rounds. Tip was looking for the empty spot to which the next jar, eleven small bluegills, should be returned. 'Would the country lay down its foreign wars, its need for health care and education, in order to turn its collective gaze to the splendours of the cod?' Tip stopped for a moment, using the buzz of the lights to work the voice out of his head. His father liked to say he paid more than forty thousand dollars a year to one of the finest universities in the world to give his son the right to peer into glass jars at dead fish.

Every jar Tip replaced introduced him to a group of specimens he had never seen before. Whenever he put a fish back he stopped to pick up three or four of its neighbours and contemplate their connections, and inevitably those connections led him to other fish, which might lead him to someday making a real scientific discovery of his own. The warmouth, for example, was in a bin next to some nearly translucent banded pygmy sunfish. Had there been more time, that would be enough to make him put the bluegill down on the floor and lift up all the sunfish. Once he got going, Tip could often manage to shoot through half a night, finally turning the lights out behind him and locking up with his own key.

19 In the passage, Tip's father is presented as

- A a tolerant and humorous presence in Tip's life.
- B constantly applying pressure on Tip to achieve at a high level in his studies.
- C someone who is attempting to do the right thing by their child, but is ignored.
- D a domineering presence in Tip's life, even though Tip attempts to ignore his influence.

- 20 'Historically, the recataloguing of fishes was work for graduate students' (line 13).
The aim of this sentence is to
- A reveal that Tip has confidence in his own capabilities at the museum.
 - B show that Tip has been given a job that is beyond his real capabilities.
 - C prove that Tip's father was correct in his estimation of Tip's role at the museum.
 - D convince the reader that recataloguing fishes is a tedious task, no matter who you are.
- 21 Tip's father's comment in lines 18–20 ('Would the country...of the cod') is most likely said in a tone of
- A outright hostility.
 - B controlled sarcasm.
 - C resentful bitterness.
 - D good-natured affection.
- 22 To Tip, the effect the 'buzz of the lights' (line 21) produces is
- A a gentle reminder.
 - B a temporary relief.
 - C a slight annoyance.
 - D an unwelcome invasion.
- 23 Which of the following phrases from the passage best captures Tip's interest in the fish at the museum?
- A 'A dozen or more tiny fish clustered together in small jars, single fish folded over in larger jars, huge fish alone in metal boxes.' (lines 6 and 7)
 - B 'Tip followed the numbers with a librarian's precision' (lines 9 and 10)
 - C 'Would the country lay down its foreign wars, its need for health care and education, in order to turn its collective gaze to the splendours of the cod?' (lines 18–20)
 - D 'he stopped to pick up three or four of its neighbours and contemplate their connections' (lines 25 and 26)

UNIT 9

Questions 24 – 28

For a number of groups of common materials, information is provided below on ranges of their *rigidity* and *density* (Figure 1), and *strength* and *true toughness* (Figure 2). This information can be used to help select materials for particular purposes.

Note: The scale on each axis is **not** linear.

In this unit:

- *rigidity* is resistance to bending due to a heavy load in gigapascals (GPa)
- *density* is mass contained in a given volume in kilograms per cubic metre (kg/m^3)
- *strength* is resistance to breaking due to a heavy load in megapascals (MPa)
- *true toughness* is ability to withstand an impact without breaking in kilojoules per square metre (kJ/m^2)

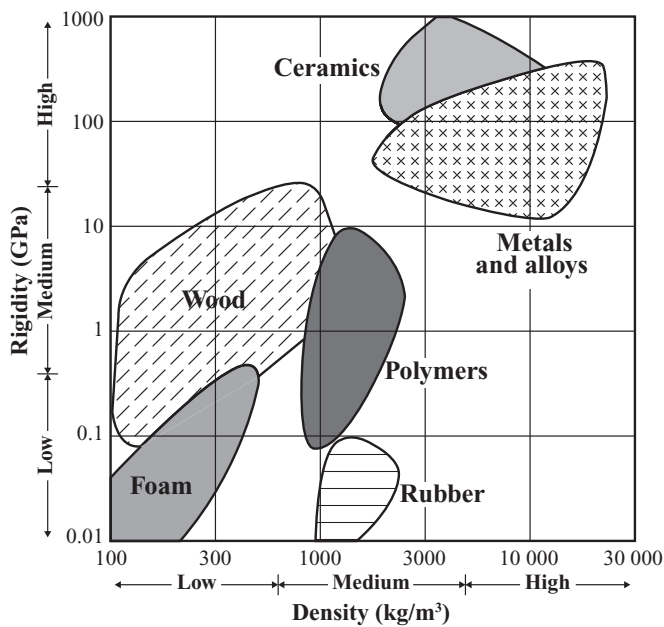

Figure 1

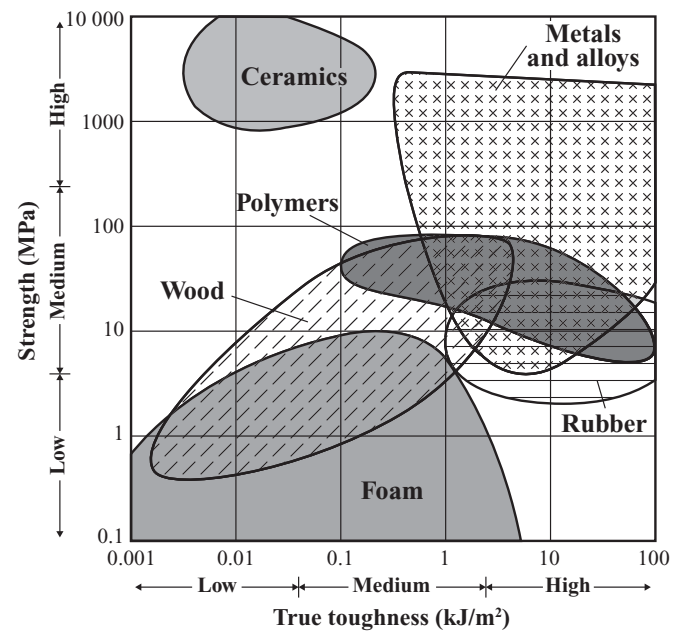

Figure 2

24 Which of the following groups contain materials which rate High in all of the four physical properties?

- A rubber
- B ceramics
- C polymers
- D metals and alloys

- 25 An object which requires Medium strength and Low density, and which must withstand medium impacts, is best made from
- A wood.
 - B rubber.
 - C ceramics.
 - D polymers.
- 26 Bicycle frames are made from metals and alloys rather than ceramics. Which of the following best explains this decision?
- A Ceramics are less dense.
 - B Ceramics are more likely to bend due to a load.
 - C Metals and alloys can support heavier loads without bending.
 - D Metals and alloys can withstand greater impacts without breaking.
- 27 Compared with materials of Low rigidity and Low density, materials with High rigidity and High density can also be distinguished because of their relatively
- A low strength.
 - B high strength.
 - C low true toughness.
 - D high true toughness.
- 28 A gardener notes that his polymer rake is not as effective as the same product made from metal. The difference is **least** likely to be the result of the polymer rake's
- A lower rigidity.
 - B lower density.
 - C lower strength.
 - D lower true toughness.

UNIT 10

Questions 29 – 31

Figure 1 and Passage 1 are about influences on health and wellbeing.

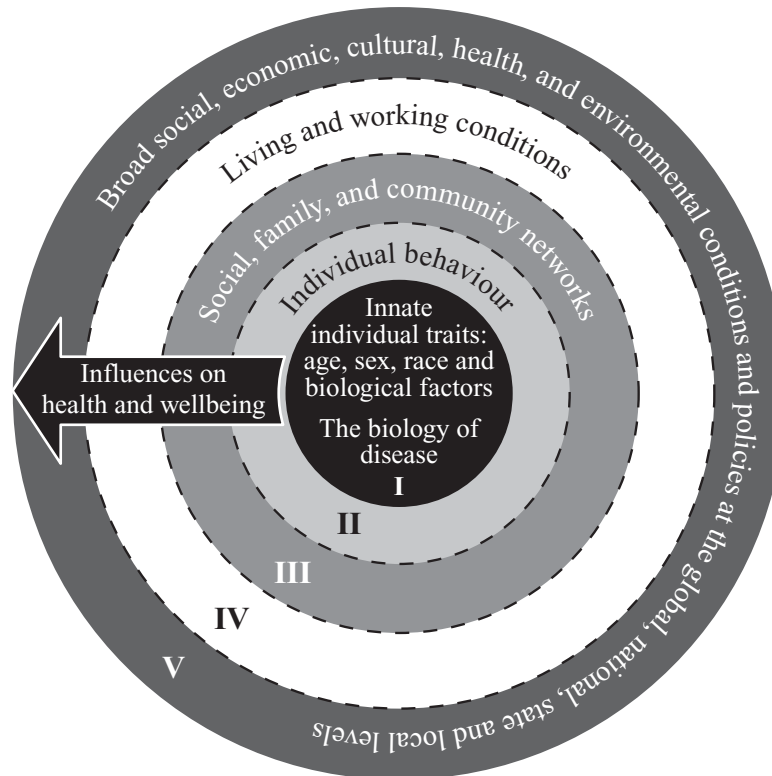

Figure 1

Passage 1

Public health campaigns to change individual behaviour have traditionally focused on the diseases themselves. Public health activities have been classified in this way, that is according to the specific disease or organ system being addressed (e.g. heart disease, arthritis, diabetes). This classification system tends to detract from efforts to promote the wellbeing of entire communities. Health promotion is more than disease prevention: it treats good health as more than just the absence of disease; it is a resource that allows people to live full, productive and satisfying lives. This reflects the World Health Organisation's definition of health as a state of complete physical, mental and social wellbeing, and not merely the absence of disease or infirmity.

- 29 In Figure 1 an individual's health is shown mostly to be a matter of
- A interaction between variables.
 - B perfect living conditions.
 - C economic constraints.
 - D genetic inheritance.

UNIT 12

Questions 35 – 36

In order to open a lock, the correct key must be inserted and turned. The lock shown in Figure 1 consists of a casing that houses a cylindrical plug. Inside the lock are five vertical cylindrical holes, each containing a spring, a driver pin and a key pin. When the correct key is inserted, the pins move upwards so that the tops of the key pins line up with the shear line. This allows the cylindrical plug to rotate when the key is turned, and the lock can be opened (Figure 2).

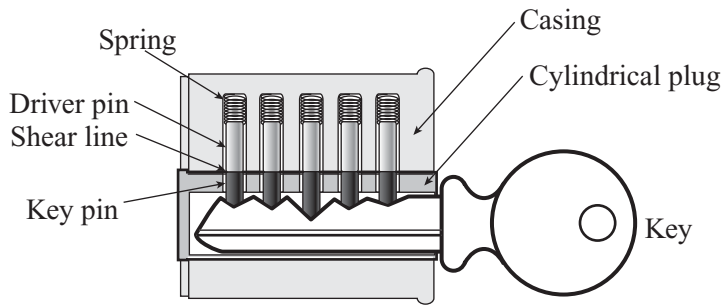

Figure 1

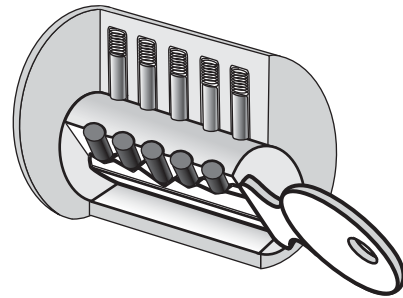

Figure 2

35 In order to open the lock in Figure 3

- A Pins II and III both need to be raised more than Pin I.
- B Pins II and III both need to be raised less than Pin I.
- C Pin II needs to be raised more than Pin I, and Pin III needs to be raised less than Pin I.
- D Pin II needs to be raised less than Pin I, and Pin III needs to be raised more than Pin I.

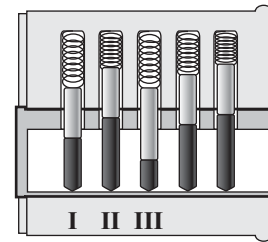

Figure 3

36 Which of these keys will most likely unlock the lock in Figure 4?

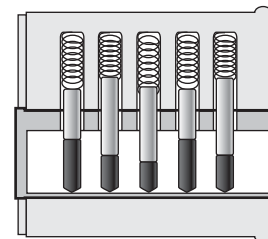

Figure 4

- A
- B
- C
- D

UNIT 13

Questions 37 – 39

Jake, Kate, Lee, Mel and Nat left Patton at 9:00 am using different forms of transport and travelled to Litton, as indicated in the figure.

Mel travelled a distance of 50 km in one hour before stopping for a rest.

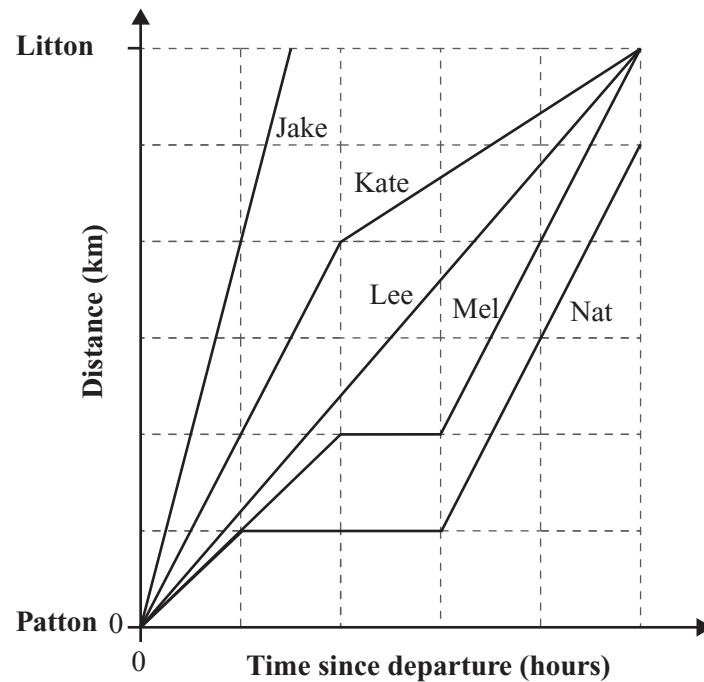

Note:

- Assume Jake, Kate, Lee, Mel and Nat each travelled in a straight line between Patton and Litton.
- The scale on each axis is linear.

37 What is the distance from Patton to Litton?

- | | |
|----------|----------|
| A 50 km | C 150 km |
| B 100 km | D 250 km |

38 What time did Kate reach Litton?

- | | |
|------------|-----------|
| A 11:30 am | C 2:00 pm |
| B 11:45 am | D 2:30 pm |

39 If Nat continued to travel at the same rate, which of the following is the best estimate of the time that she would reach Litton?

- | | |
|------------|-----------|
| A 11:30 am | C 2:00 pm |
| B 11:45 am | D 2:30 pm |

UNIT 14

Questions 40 – 44

The cruel girls we loved
Are over forty,
Their subtle daughters
Have stolen their beauty;

And with a blue stare
Of cool surprise,
They mock their anxious mothers
With their mothers' eyes.

5

David Campbell

- 40 The poem suggests mothers and daughters are
- A allies.
 - B rivals.
 - C opposites.
 - D soul mates.
- 41 The poet believes
- A the mothers need more power.
 - B the daughters have inappropriate power.
 - C it is inevitable the daughters have the attitude they do.
 - D it is unforgivable that the daughters do not respect their mothers as they should.
- 42 In line 1 the mothers are described as 'cruel'.
This is probably a direct result of the poet's own
- A prejudices.
 - B predictions.
 - C imagination.
 - D experiences.

- 43 In line 7 the daughters ‘mock’ their mothers.
This shows the daughters are
- A attempting to be amusing.
 - B judging their mothers’ desperation.
 - C jealous of their mothers’ youthfulness.
 - D embarrassed by their mothers’ scrutiny.
- 44 Which of the following comments best reflects the main idea in the poem?
- A Maturity can bring painful uncertainty.
 - B Maturity brings with it a sense of security.
 - C If one is insecure, one can never be mature.
 - D Maturity is simply the name we give to our mistakes.

UNIT 15

Question 45

- 45 Knowledge can be communicated, but not wisdom.

Hermann Hesse

This statement suggests that wisdom

- A leads to knowledge.
- B is not knowledge.
- C depends on knowledge.
- D is gained through knowledge.

UNIT 16

Question 46

- 46 Which one of the following proverbs contrasts with the other three?
- A A thing of beauty is a joy for ever.
 - B Beauty is only skin deep.
 - C Beauty is no inheritance.
 - D Please your eye and plague your heart.

UNIT 17

Questions 47 – 49

Hand-operated ventilation pumps are installed in the wall spaces between two rooms of storm shelters so that fresh air can be pumped into the shelter without the need to open a door. The pump is operated by a handle that is moved in and out to draw outside air into the shelter. The handle is connected to a rubber seal in the air chamber.

The figures show cross sections of a ventilation pump, indicating the flow of air, and the position of six flapper valves (P, Q, R, S, T and U) during successive in (Figure 1) and out (Figure 2) movements of the handle. Note that each flapper valve opens in only one direction.

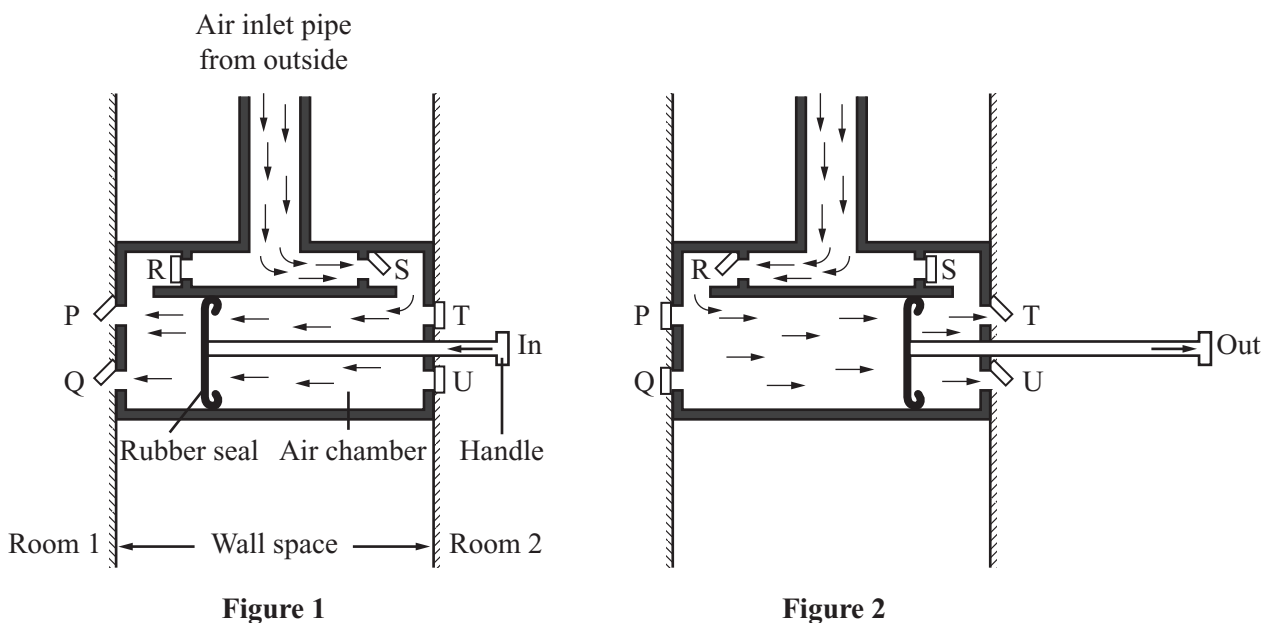

Figure 1

Figure 2

- 47 This ventilation pump is designed so that air is drawn through the air inlet pipe
- when the handle is pushed in only.
 - when the handle is pulled out only.
 - when the handle is both pushed in and pulled out.
 - in none of the above situations.
- 48 Suppose that the direction of air flow in the pump is to be reversed, so that when the handle is moved in and out, air is drawn from both rooms in the shelter and pumped out through the air inlet pipe.
- Which of the following modifications would best achieve this?
- Flapper valves P, Q and R only must open in the opposite direction.
 - Flapper valves P, Q, T and U only must open in the opposite direction.
 - Flapper valves P, Q, R, S, T and U must open in the opposite direction.
 - It is not possible to reverse the direction of the air flow.

49 Suppose flapper valve R becomes stuck closed.

Which of the following would allow fresh air to be pumped into Room 1?

- A Flapper valve S only must be held open as the handle is pulled out.
- B Flapper valves T and U only must be held open as the handle is pushed in.
- C Flapper valves P and R only must be held open as the handle is pulled out.
- D None of the above would allow fresh air to be pumped into Room 1.

UNIT 18

Questions 50 – 51

The figure shows the first three steps (starting from ground level) of a spiral staircase of radius 100 cm (1 m) that fits exactly within a 2-metre wide cylindrical tower. Each step has a 20 cm vertical rise.

- Radius of a circle = r
- Circumference of a circle = $2\pi r$, where $\pi \approx 3.14$
- Area of a circle = πr^2

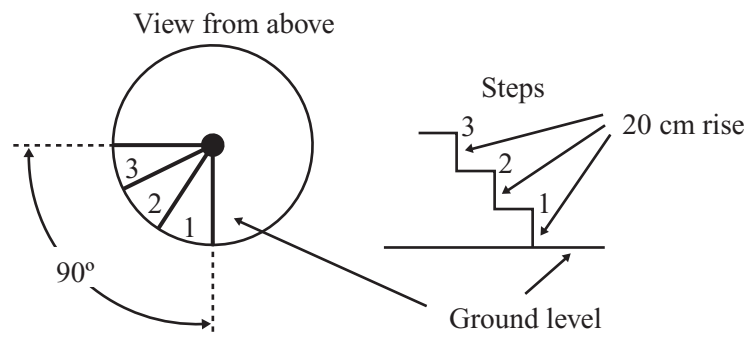

50 After a full circle of steps, what is the height of the top of the highest step above ground level?

- A 120 cm
- B 180 cm
- C 240 cm
- D 270 cm

51 If no part of any step is directly above any part of another step, which one of the following is the best estimate of the area of the top of a step?

- A 0.25 square metres
- B 0.50 square metres
- C 0.75 square metres
- D 1.00 square metre

UNIT 19**Questions 52 – 55**

The following questions 52 – 55 are from a debate for and against the topic:

The Internet should be censored.

For each of the questions 52 – 55 you are to choose the alternative (A–D) that most appropriately describes the relationship of the statement to the topic of the debate.

The statement:

- A is most likely part of the debate **for** the topic.
- B is most likely part of the debate **against** the topic.
- C could possibly be part of the debate **for or against** the topic.
- D is **not relevant** to either the debate for or against the topic.

52 Total freedom leads to total vice.

53 Those who use the Internet should decide its content.

54 People already spend too much time on the Internet.

55 That which is forbidden only becomes more tempting.

UNIT 20

Questions 56 – 59

The following passage is taken from a book about ecology and the environment.

Wetlands are not always, and for some not ever, the most pleasant of places. In fact, they have often been seen as horrific places. In western cultural tradition, wetlands have been associated with death and disease, the monstrous and the melancholic, if not the downright mad. Wetlands are ‘black waters’. They have even been seen as a threat to health and sanity, to the clean and proper body and mind. The typical response to the horrors and threats posed by wetlands has been simple and decisive: dredge, drain or fill and so ‘reclaim’ them. Yet the idea of reclaiming wetlands begs the questions of reclaimed from what? for what? from whom? A critical history of wetlands’ drainage could quite easily be entitled ‘Discipline and Drain’.

5

- 56 According to the writer, the traditional western response to wetlands has been
- A uncompromising.
 - B apathetic.
 - C rational.
 - D neutral.
- 57 The writer suggests that in the past, people have wanted to
- A extend wetlands.
 - B abandon wetlands.
 - C preserve wetlands.
 - D gain control of wetlands.
- 58 According to the writer, wetlands
- A should be made useful and productive.
 - B have been imbued with a moral dimension.
 - C are neglected wastelands.
 - D do cause madness.
- 59 When the writer argues that a critical history of wetland drainage could be entitled ‘Discipline and Drain’, he suggests that the reclamation of wetlands is
- A chaotic.
 - B logical.
 - C authoritarian.
 - D understandable.

UNIT 21

Questions 60 – 63

The figure represents a prediction, made in 2006, for GDP growth versus consumer spending growth in 2011. GDP means gross domestic product, which is a measure of the value of all goods and services produced by a country or group of countries.

- Bubble size is directly proportional to predicted GDP in 2011.
- ‘Asia’ means Asian countries other than those specifically mentioned.

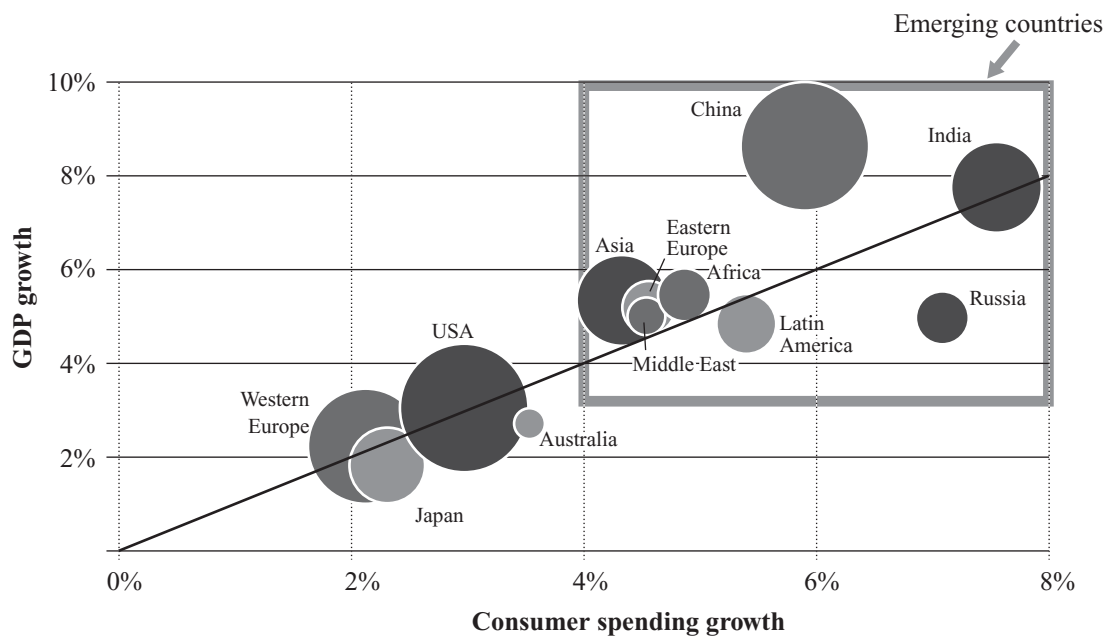

- 60 According to the prediction, in contrast with China, in 2011 Russia will have greater
- A GDP.
 - B consumer spending.
 - C percentage GDP growth.
 - D percentage consumer spending growth.
- 61 According to the prediction, which of the following will have the greatest GDP in 2011?
- A India
 - B Russia
 - C USA
 - D It is not possible to determine this from the information given.

62 According to the prediction, for Australia the percentage growth in consumer spending in 2011 will be

- A** less than its percentage growth in GDP.
- B** greater than its percentage growth in GDP.
- C** less than the USA percentage growth in consumer spending.
- D** less than the Japanese percentage growth in GDP.

63 Which of the following best illustrates what is meant by the comment: ‘Emerging countries will drive the world economy.’?

Compared with the USA, for emerging countries in general in 2011

- A** GDP will be greater.
- B** consumer spending will be greater.
- C** percentage growth in both consumer spending and GDP will be greater.
- D** the ratio of percentage growth in consumer spending to percentage growth in GDP will be greater.

UNIT 22

Questions 64 – 66

A class tests five white powders to see if they dissolve in two liquids, X and Y (**Test i** and **Test ii**). They also test the reaction of the powders with an acid (**Test iii**). The results are shown in Table 1.

Liquids X and Y are not acids.

Table 1

	Test i Adding powder to liquid X		Test ii Adding powder to liquid Y		Test iii Adding powder to an acid
	Dissolves in liquid X	Floats or sinks in liquid X	Dissolves in liquid Y	Floats or sinks in liquid Y	Result
Powder I	yes	-	yes	-	fizz
Powder II	yes	-	no	floats	no fizz
Powder III	no	sinks	no	sinks	no fizz
Powder IV	no	floats	yes	-	no fizz
Powder V	yes	-	no	sinks	fizz

The class then tests five mixtures of powders, each of which contains **two** of the five white powders. The results are shown in Table 2.

Table 2

	Test i Adding powder to liquid X		Test ii Adding powder to liquid Y		Test iii Adding powder to an acid
	Dissolves in liquid X	Floats or sinks in liquid X	Dissolves in liquid Y	Floats or sinks in liquid Y	Result
Mixture I	yes	-	some dissolves	some floats	fizz
Mixture II	some dissolves	some floats	some dissolves	some floats	no fizz
Mixture III	no	some floats, some sinks	some dissolves	some sinks	no fizz
Mixture IV	yes	-	some dissolves	some sinks	fizz
Mixture V	yes	-	no	some floats, some sinks	fizz

- 64 What is in **Mixture II**?
- A **Powders II and IV**
 - B **Powders II and V**
 - C **Powders III and IV**
 - D **Powders III and V**
- 65 Given the results in Table 1, if the class had **only** done **Test i** on **Mixture I**, what could be concluded?
- A **Mixture I** contains **Powder I** and **Powder II**.
 - B **Mixture I** contains **Powder III** and **Powder IV**.
 - C **Mixture I** contains two of **Powders I, II** and **V**.
 - D None of the above conclusions is justified.
- 66 Given the results in Table 1, what is the minimum number of the three tests required to determine the powders in **Mixture III**?
- A one
 - B two
 - C three
 - D The powders in **Mixture III** cannot be determined.

UNIT 23

Questions 67 – 70 refer to the text below and the text and image on the following page.

*Pop art is a style of art which seeks its inspiration from commercial art and items of mass culture. In 1961, the American pop artist Roy Lichtenstein created the picture, **Girl with a Ball**. He took the image of the girl straight from a photograph that appeared in an advertisement for a hotel. This artwork was the subject of much critical review. The following page contains the image **Girl with a Ball** and the comments of two art critics.*

67 Critic One objects to the image primarily because he thinks

- A it is difficult to understand.
- B the subject matter is immoral.
- C the artist lacked technical skill.
- D it does not conform to his perception of art.

68 Critic One believes that art

- A should appeal to a mass market.
- B is a concept open to interpretation.
- C has certain parameters and constraints.
- D can be derivative and innovative at the same time.

69 According to Critic Two, the simplicity of the image is

- A puzzling.
- B deceptive.
- C unoriginal.
- D unimportant.

70 Critics One and Two agree that the image is

- A borrowed.
- B immature.
- C idealistic.
- D creative.



Critic One

Roy Lichtenstein's image, *Girl with a Ball*, reduces art to the dismal level of the comic strip. There is little that is original in an image that was pilfered from an advertising board and it represents the worst of middle-brow, mass culture. The flat and vacuous figure in the sterile background is as devoid of intellect as it is of emotion, and art without feeling can never move the viewer. Any artist who purports to find meaning in the junk he is supposed to have outgrown is hardly an artist at all. Someone should tell him that advertisements are illegitimate subjects for art and comic strips do not belong on the walls of galleries and museums.

Critic Two

In *Girl with a Ball*, Roy Lichtenstein transforms the pirated image of a girl with a beach ball, submitting the original photograph to the techniques of the comic-strip artist and the printer. The resulting simplifications intensify the artifice and meaning of the picture, curdling its careful dream of fun in the sun. The girl's rounded mouth is more doll-like than female; any sex appeal she had has become as plastic as her beach ball. The self-conscious, moral seriousness of art and the unquestioned assumptions about art's longevity are parodied by this apparently cheap, transient advertisement from the consumer marketplace.

ACER thanks rights holders who have kindly granted permission to reproduce the material cited below. Every effort has been made to trace and acknowledge copyright. However, should any infringement have occurred, ACER tenders its apology and invites copyright owners to contact ACER at permissions@acer.edu.au.

ACKNOWLEDGMENTS — Angus & Robertson (Harper Collins Aust) for the poem *Mothers and Daughters* by David Campbell; Isabelle Bannerman, at CartoonStock for the cartoon *Urban Relaxation*; Anne Patchett and ICM, New York for extract from *Run*; Cunningham, B.W., DiStefano, A.F., Kirjanov, N.A., Lavine, S.E. and Schon, L.C., 1998. A comparative mechanical analysis of the pointe shoe toe box: an in vitro study. *The American Journal of Sports Medicine*, Vol 26, No. 4, pp. 555-561, for Pointe Shoe unit; Scala Group S.P.A. Firenze: http://www.moma.org/collection/browse_results.php?object_id=79665 for the reproduction of *Girl with Ball 1961*; <http://www-materials.eng.cam.ac.uk/mpsite/physics/introduction/default.html>, accessed 7/02/2008, for Materials selection unit.